



GUIDE SPECIFICATIONS

EM Series 6-30 Large Commercial

GENERAL

Units shall be performance certified to ISO standard 13256-1 for Water Loop Heat Pump, Ground Water Heat Pump and Ground Loop Heat Pump applications for units up to 10 tons. Units intended for use on ground loop applications shall have an optional extended range package installed which consists of an insulated water to refrigerant heat exchanger. Units shall be Underwriter Laboratories (UL and cUL) listed for safety on all models. Each unit shall be run tested at the factory. Each unit shall be pallet mounted and stretch wrapped. The units shall be manufactured in an ISO9001:2000 certified facility.

The units shall be warranted by the manufacturer against defects in materials and workmanship for a period of one year on all parts, and 5 years on the compressor.

The units shall be designed to operate with entering fluid temperatures between 50°F (10°C) and 100°F (38°C) in cooling and between 50°F (10°C) and 80°F (27°C) in heating. With the optional factory installed extended range package units shall operate with entering fluid temperatures between 50°F (10°C) and 110°F (43.3°C) in cooling and between 25°F (-3.9°C) and 80°F (27°C) in heating.

CASING & CABINET

The cabinet shall be fabricated from heavy-gauge galvanized steel. The interior shall be insulated with ½" (12.7mm) thick, multi density, coated, glass fiber. All units shall allow sufficient service access to replace the compressors without unit removal. Two blower and two compressor compartment access panels shall be removable with supply and return ductwork in place. A duct collar shall be provided on the supply air opening of all vertical units. A 2" (50.8mm) return air filter rack/duct collar with 1" (25.4mm) thick filters shall be provided with each unit. Vertical units shall have an insulated divider panel between the air handling section and the compressor section to minimize the transmission of compressor noise, and to permit operational service testing without air bypass. Units shall have stainless steel condensate drain pan(s).

REFRIGERATION CIRCUITS

All units shall contain sealed refrigerant circuits including hermetic compressors, thermal expansion valve metering devices, finned tube air-to-refrigerant heat exchangers, refrigerant reversing valves and service ports. Compressors shall be high efficiency, designed for heat pump duty, internally spring isolated (except for scroll type compressors) for maximum sound attenuation and mounted on rubber vibration isolators. Compressor motors shall be equipped with overload protection. Refrigerant reversing valves shall be pilot operated sliding piston type with replaceable encapsulated magnetic coils energized only during the cooling cycle. The finned tube coil shall be constructed of lanced aluminum fins not exceeding fourteen fins per inch bonded to rifled copper tubes in a staggered pattern not less than three rows deep and have a 450 PSIG (3100 kPa) working pressure. Coils shall have a baked polyester enamel coating for protection against most airborne

chemicals. Coils shall have aluminum end sheets. The coaxial water-to-refrigerant heat exchangers shall be constructed of a convoluted copper (optional cupro-nickel) inner tube and steel outer tube with a designed refrigerant working pressure of 450 PSIG (3100 kPa) and a designed water side working pressure of no less than 400 PSIG (2750 kPa).

FAN MOTOR & ASSEMBLY(S)

The fan(s) shall be belt driven DWDI forward curved type with dynamically balanced wheel(s). The housing(s) and wheel(s) shall be designed for quiet low velocity operation. The fan housing(s) shall be removable from the unit without disconnecting the supply air ductwork for servicing of the fan motor(s). The fan motor(s) shall be 1725 or 3450 RPM 56 frame sealed ball bearing type. The motor(s) shall be permanently lubricated and have thermal overload protection.

ELECTRICAL

Controls and safety devices will be factory wired and mounted within the unit. Controls shall include fan relay(s), compressor contactors, 24V transformer, reversing valve coils and a solid state lock-out control circuit (UPM). The UPM controller shall include the following features: Anti-short cycle time delay, random start, interstage delay, brown out/surge/power interruption protection, 120 second low pressure switch bypass timer, shutdown on high or low refrigerant pressure safety switch inputs, shutdown for the optional freezestat or high level condensate sensors, 24 VAC alarm output for remote fault indication, unit reset at thermostat or disconnect, ability to defeat time delays for servicing, time delay between stages and automatic intelligent reset. The UPM shall automatically reset after a safety shut down and restart the unit, if the cause of the shut down no longer exists, after the anti-short cycle and random start timers expire. Should a fault re-occur within 60 minutes after reset, then a permanent lockout will occur. A light emitting diode (LED) shall annunciate the following alarms for each refrigerant circuit: high refrigerant pressure, low refrigerant pressure, low water temperature and a high level of condensate in the drain pan (when equipped with the optional low water temperature and high level condensate sensors). The LED will display each fault condition as soon as the fault occurs. If a permanent lockout occurs, then the fault LED will display the type of fault until the unit is reset. Safety devices include a low pressure cutout set at 20 PSIG (140 kPa) for loss of charge protection (a freezestat used for loss of charge protection is not acceptable) and a high pressure cutout control set at 380 PSIG (2600 kPa). An optional energy management relay to allow unit control by an external source shall be factory installed.

PIPING

Supply, return water and condensate drain connections shall be copper or brass female pipe thread fittings and mounted flush to cabinet exterior.



FHP Manufacturing Co.
 601 N.W. 65th Court
 Fort Lauderdale, FL 33309
 Phone: (954) 776-5471
 Fax: (800) 776-5529
<http://www.fhp-mfg.com>

EM072-120 Vertical Dimensions

Single Blower Large Commercial Units

Dimensions			
All Dimensions +/- 0.125"			
Dimension	Model		
	-072	-096	-120
Height	62.00	62.00	62.00
Width	42.00	42.00	42.00
Depth	32.00	32.00	32.00
Condenser Connections			
A	14.75	14.75	15.00
B	8.50	8.50	9.00
C	2.75	2.75	3.00
Dia. (FPT)	1.00"	1.00"	1.50"
Return Air Opening			
D(Duct Flange)	38.00	38.00	38.00
E(Filter Rack)	40.00	40.00	40.00
Replacement Filter Size			
-072 through -120 20 x 34-1/2 x 1 (2 per unit)			
Service Access			
Panel #	Access To:		
1	Controls, Compressors, Refrigeration Components		
2	Blower & Motor		
3	Blower		

Front Return

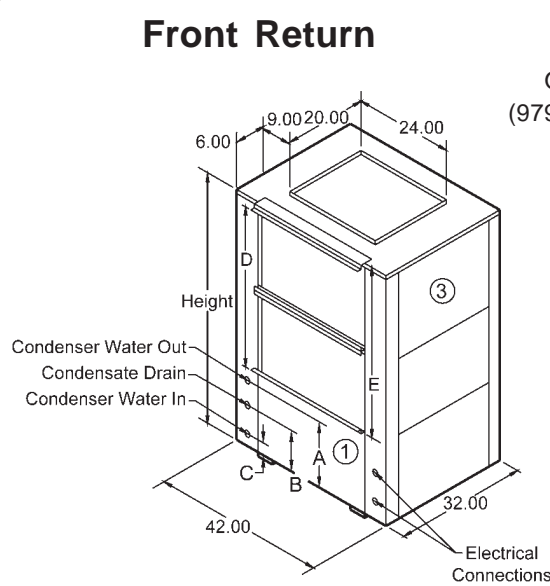

Optional Blower Orientation (979-032) Standard Blower Orientation

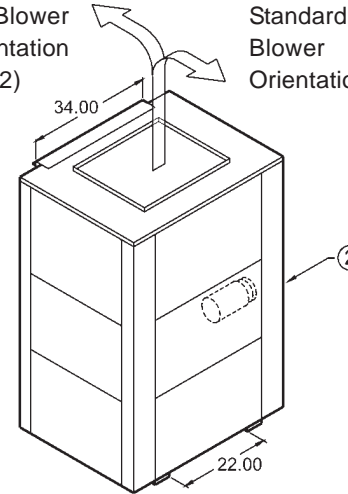

Top Supply (FFT)

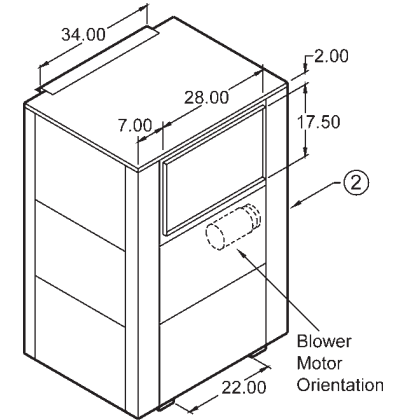

Rear Supply (FFR)

Rear Return

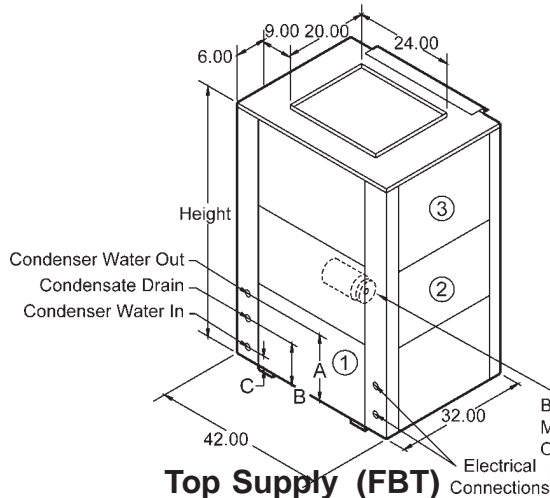

Top Supply (FBT)

Standard Blower Orientation Optional Blower Orientation (979-032)

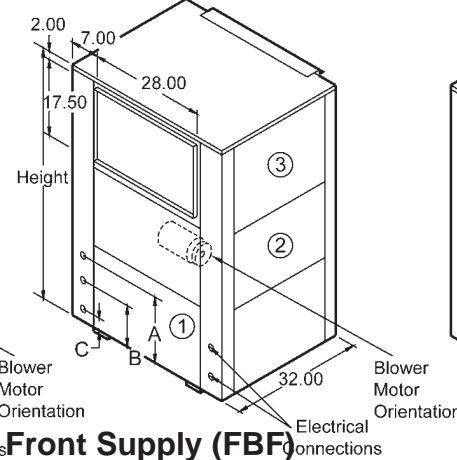

Front Supply (FBF)

Notes: Condensate connections are 0.75" FPT on -072 through -120 and 1.25" FPT on -150 and -180. Due to continuing research and development, specifications are subject to change without notice.



FHP Manufacturing Co.
 601 N.W. 65th Court
 Fort Lauderdale, FL 33309
 Phone: (954) 776-5471
 Fax: (800) 776-5529
<http://www.fhp-mfg.com>

EM072-140 Horizontal Dimensions

Dimensions				
All Dimensions +/- 0.125"				
Dimension	-072	-096	-120	-140
Height	21.50	21.50	21.50	25.50
Width	38.00	38.00	38.00	42.00
Depth	78.00	78.00	78.00	82.00
Return Air Dimensions				
A	2.00	2.00	2.00	2.00
B	20.50	20.50	20.50	24.00
C	18.50	18.50	18.50	22.00
Condenser Connections				
E	26.25	26.25	27.50	22.50
F	2.75	2.75	3.38	2.75
G	37.50	37.50	38.25	30.75
H	14.50	19.25	16.75	18.25
Diameter	1"FPT	1"FPT	1.25"FPT	1.50"FPT
Supply Air Dimensions (Blower Outlet)				
J	15.50	15.50	12.50	18.50
K	13.50	13.50	13.50	16.00
L	10.50	10.50	5.25	14.00
Replacement Filter Size				
072-120	20 x 34-1/2 x 1 (2 per unit)			
140	24 x 34 x 1 (2 per unit)			
Service Access				
Panel#	Access To:			
1	Controls, Compressors			
2	Blower & Motor			
3	Compressors, Refrigeration Components			

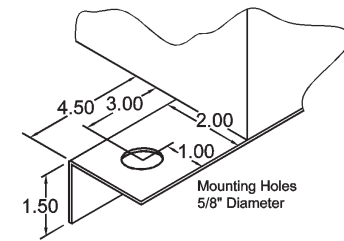
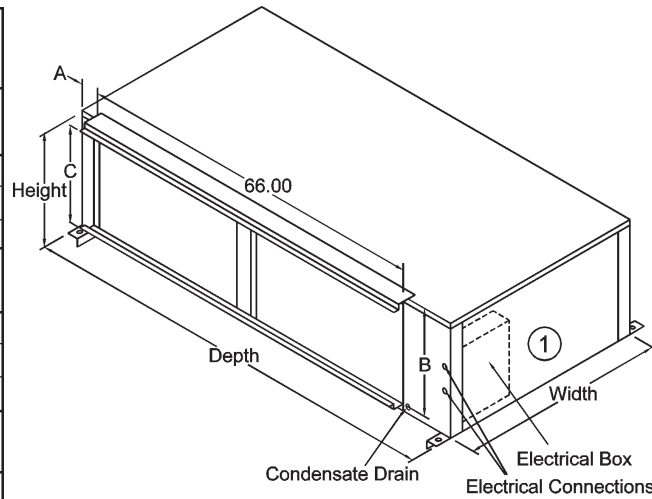

MOUNTING BRACKET SECTION VIEW

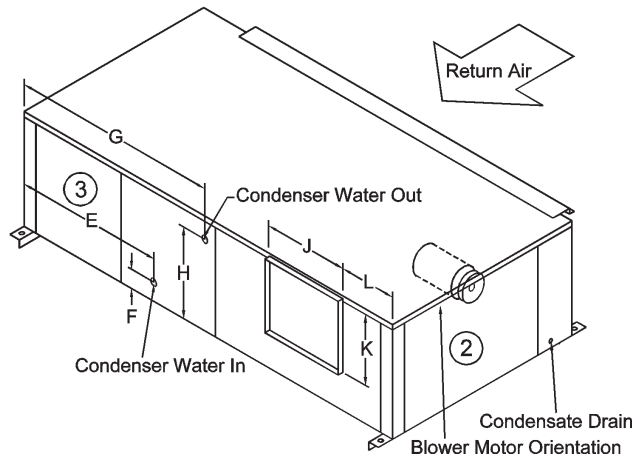

072, 096 & 140 (-SLS Only)

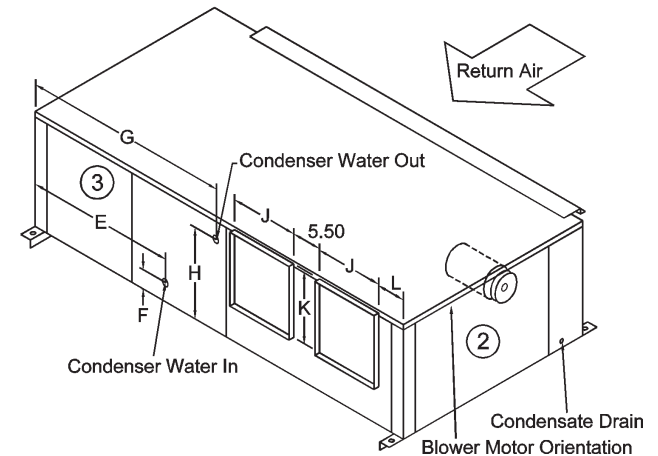

120 (-SLS Only)

Notes: All condensate connections are 0.75" FPT.
 Due to continuing research and development, specifications are subject to change without notice.



FHP Manufacturing Co.
 601 N.W. 65th Court
 Fort Lauderdale, FL 33309
 Phone: (954) 776-5471
 Fax: (800) 776-5529
<http://www.fhp-mfg.com>

EM170-242 Horizontal Dimensions

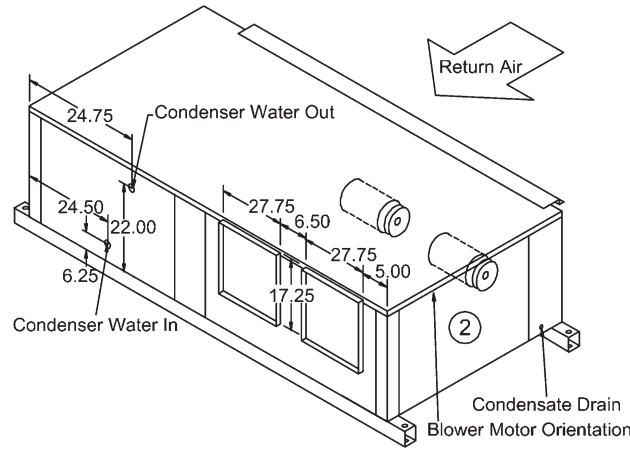
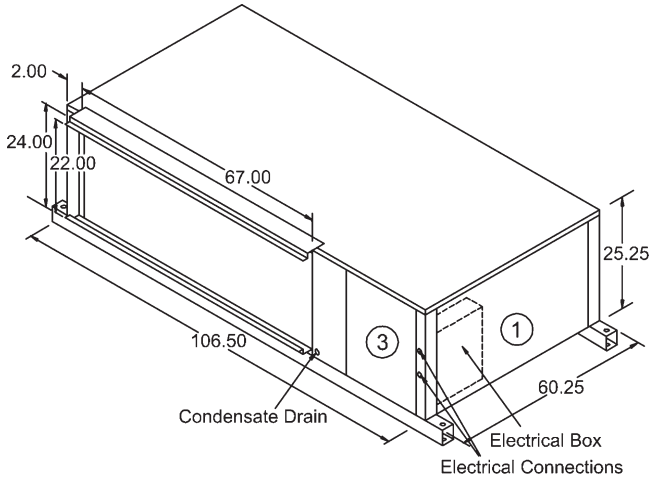

EM170 SLS CONFIGURATION ONLY

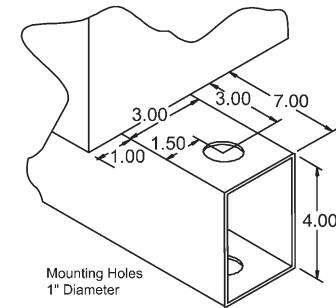

MOUNTING BRACKET SECTION VIEW

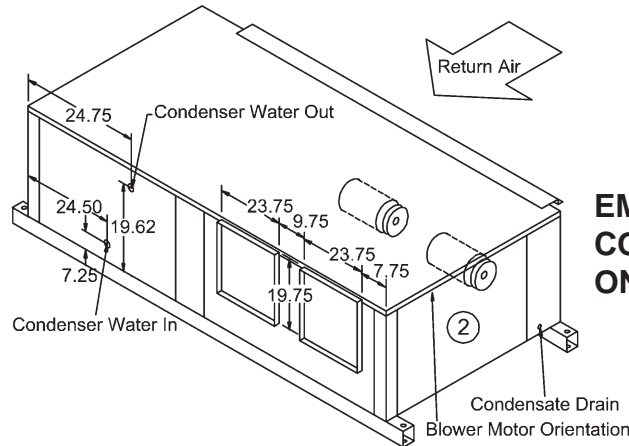
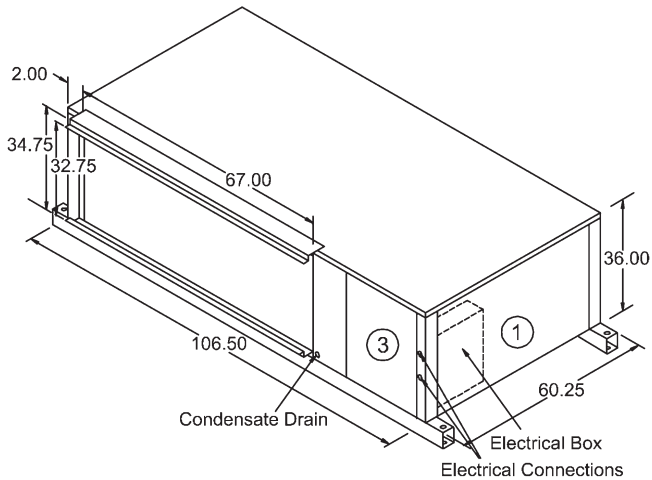

EM242 SLS CONFIGURATION ONLY

Dimensions

Condenser Connections

EM170	1.50" FPT
EM242	2.00" FPT

Replacement Filter Size

EM170	24 x 34 x 1 (2)
EM242	20 x 34-1/2 x 1 (4)

Service Access

Panel#	Access To:
1	Controls, Compressors, Refrigeration Components
2	Blowers & Motors
3	Compressors, Refrigeration Components

Notes: All dimensions +/- 0.125".
 All condensate connections are 1.25" FPT.
 Due to continuing research and development, specifications are subject to change without notice.



FHP Manufacturing Co.
 601 N.W. 65th Court
 Fort Lauderdale, FL 33309
 Phone: (954) 776-5471
 Fax: (800) 776-5529
<http://www.fhp-mfg.com>

EM144-360 Vertical Dimensions

Dual Blower Large Commercial Units

Dimensions						
All Dimensions +/- 0.125"						
Model	Height	A	B	C	D	E
144	62.00	17.00	10.50	3.00	40.00	38.00
168	62.00	17.00	10.50	3.00	40.00	38.00
210	62.00	14.75	8.50	2.75	40.00	38.00
240	66.50	14.75	8.75	2.75	40.00	38.00
300	66.50	14.75	8.75	2.75	40.00	38.00
360	86.50	15.00	9.00	3.50	60.00	58.00
Model	Condenser Connection Diameter		Condensate Drain Diameter			
144	1.50"FPT		1.25"FPT			
168	1.50"FPT		1.25"FPT			
210	2.00"FPT		1.25"FPT			
240	2.00"FPT		1.25"FPT			
300	2.00"FPT		1.25"FPT			
360	2.00"FPT		1.25"FPT			
Supply Air Duct Collar Location (F)						
Standard Blower Orientation					6.00	
Optional Blower Orientation					11.00	
Recommended Replacement Filter Size (Nominal)						
20 x 34-1/2 x 1 (4 per unit, 144-300)						
30 x 34-1/2 x 1 (4 per unit, 360)						
Service Access						
Panel #	Access To:					
1	Controls, Compressors, Refrigeration Components					
2	Blower & Motor					
3	Blower					

Front Return Top Supply (FFT)

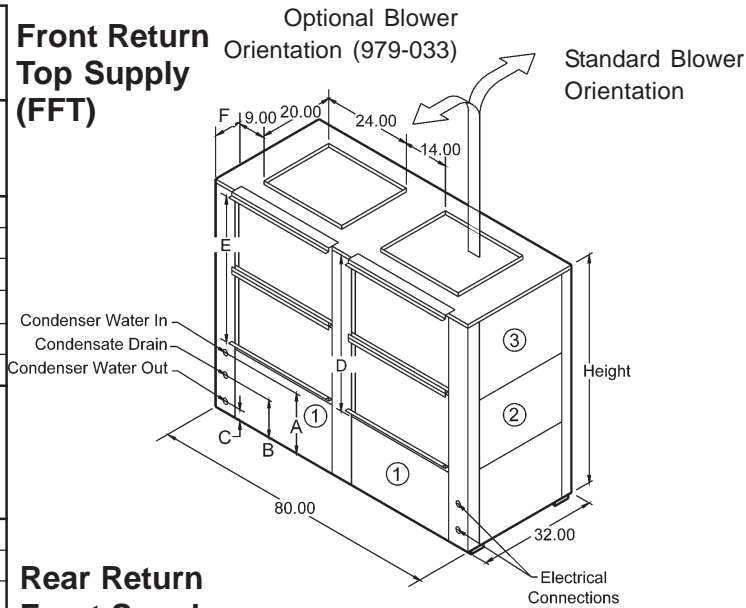

Rear Return Front Supply (RFB)

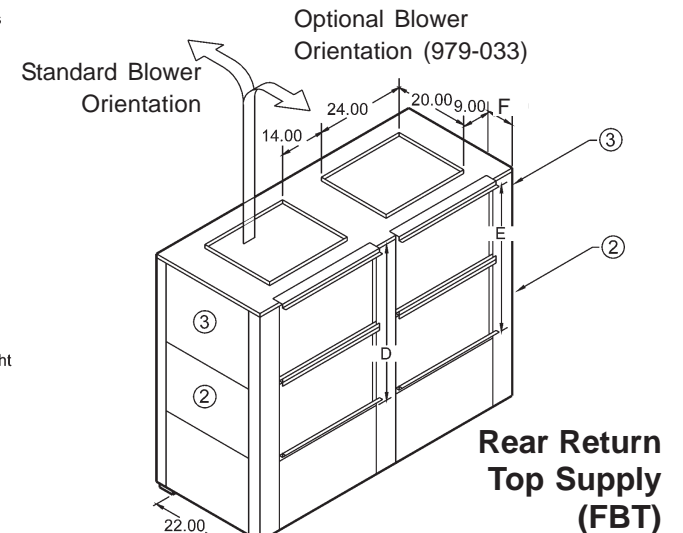
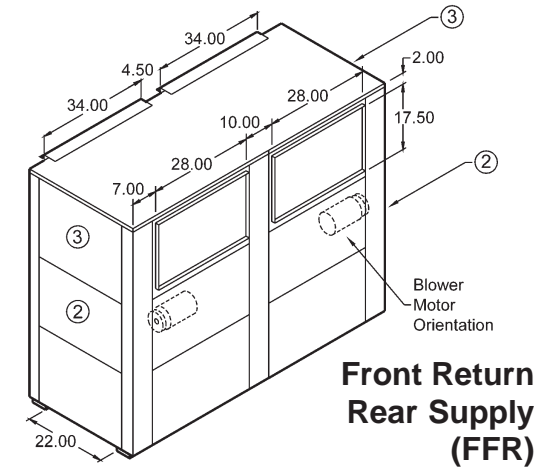
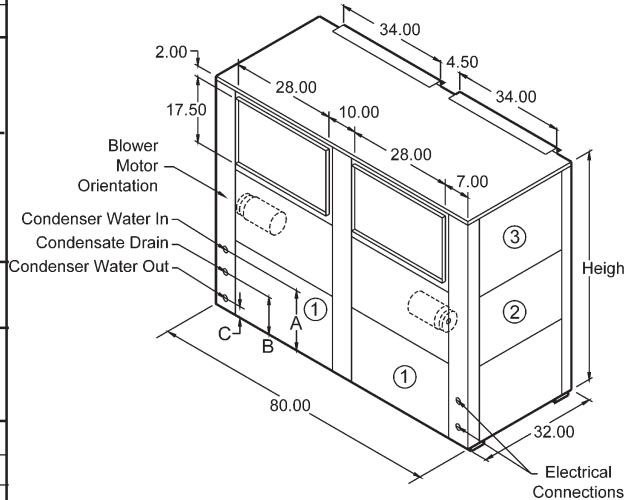

Due to continuing research and development, specifications are subject to change with out notice.



2 STAGE PACKAGED UNITS SPECIFICATION DATA SHEET

FHP MANUFACTURING HIGH-EFFICIENCY WATER SOURCE HEAT PUMPS

EM072

ENERGY-MISER

ELECTRICAL SPECIFICATIONS

Electrical Characteristics	Elect. Symbol	Compressor (x2)		Blower		Loop Pump		Min. Circuit Amps	Max. Fuse/Breaker
		RLA	LRA	FLA	HP	FLA	HP		
208/230-1-60	-1	14.7	74.0	7.5	1	-	-	40.6	50
208/230-3-60	-3	9.3	68.0	3.6	1	-	-	24.5	35
460-3-60	-4	5.0	36.0	1.8	1	-	-	13.1	15

MECHANICAL SPECIFICATIONS

Refrigerant: R-22			
Air Coil			
Square Feet	Rows Deep	Tube O.D.	Fins/Inch
7.00	3	3/8	14
Water Coil			
Type	Work Press		
Coaxial	450 psig		
Blower Size	Compr Type		
12x12 BD	Reciprocating		
Net Weight	Ship Weight		
631 lbs	676 lbs		

BLOWER PERFORMANCE

Available External Static Pressure (Inches of Water, Gauge. Wet Coil and Filter Included)												
Motor Sheave	0.10	0.20	0.30	0.40	0.50	0.60	0.70	0.80	0.90	1.00	1.10	1.20
Closed	-	-	-	-	-	-	-	-	2420	2160	1900	1700
1/2 Open	-	-	2980	2800	2610	2400	2100	1800	-	-	-	-
Open	2780	2590	2350	2050	1780	-	-	-	-	-	-	-



ISO 13256-1 CERTIFIED PERFORMANCE DATA Rated at 2,300 CFM and 16.0 GPM

Water Loop				Ground Water				Ground Loop (Ext. Range Required)			
Cooling		Heating		Cooling		Heating		Cooling		Heating	
Capacity	EER	Capacity	COP	Capacity	EER	Capacity	COP	Capacity	EER	Capacity	COP
71,000	14.0	72,000	4.6	81,000	18.0	60,000	4.1	73,000	15.8	47,000	3.6

FLUID PRESSURE DROP

Fluid Flow (GPM)	Pressure Drop	
	(FOH)	(PSIG)
10	6.0	2.6
12	8.3	3.6
14	11.0	4.8
16	14.0	6.1
18	17.3	7.5

CAPACITY DATA All performance at 2,300 CFM and 16.0 GPM

COOLING							
EFT Range (Standard) 50°F to 100°F				EFT Range (Ext. Range Option) 45°F to 110°F			
Entering Fluid Temp. (°F)	Entering Air Temp. (°F)	Total Capacity (MBtuH)	Sensible Capacity (MBtuH)	Sensible to Total Ratio	Power Input (kW)	Heat of Reject (MBtuH)	EER
50°	70°db	71.38	47.15	0.66	4.38	86.34	16.3
60°		68.21	45.43	0.67	4.57	83.81	14.9
70°		65.03	43.85	0.67	4.76	81.28	13.7
85°		60.27	41.71	0.69	5.04	77.49	12.0
100°		55.51	39.76	0.72	5.33	73.69	10.4
50°	75°db	76.48	56.38	0.74	4.41	91.53	17.3
60°		73.09	54.32	0.74	4.60	88.78	15.9
70°		69.69	52.44	0.75	4.79	86.03	14.6
85°		64.59	49.89	0.77	5.07	81.90	12.7
100°		59.50	47.56	0.80	5.36	77.78	11.1
50°	80°db	83.95	62.24	0.74	4.44	99.11	18.9
60°		80.22	59.98	0.75	4.63	96.04	17.3
70°		76.50	57.91	0.76	4.83	92.97	15.9
85°		70.92	55.10	0.78	5.11	88.36	13.9
100°		65.33	52.53	0.80	5.40	83.75	12.1
50°	85°db	91.41	68.17	0.75	4.48	106.69	20.4
60°		87.36	65.69	0.75	4.67	103.30	18.7
70°		83.31	63.43	0.76	4.86	99.91	17.1
85°		77.24	60.35	0.78	5.15	94.82	15.0
100°		71.16	57.55	0.81	5.44	89.73	13.1

HEATING

HEATING					
EFT Range (Standard) 50°F to 80°F			EFT Range (Ext. Range Option) 25°F to 80°F		
Entering Fluid Temp. (°F)	Entering Air Temp. (°F)	Total Capacity (MBtuH)	Power Input (kW)	Heat of Abs. (MBtuH)	COP
50°	60°	63.78	4.44	48.61	4.2
60°		70.76	4.65	54.89	4.5
70°		77.75	4.86	61.17	4.7
80°		84.74	5.07	67.44	4.9
50°	70°	60.31	4.52	44.88	3.9
60°		66.91	4.73	50.75	4.1
70°		73.51	4.95	56.63	4.4
80°		80.11	5.16	62.51	4.6
50°	80°	56.24	4.62	40.47	3.6
60°		62.39	4.84	45.88	3.8
70°		68.54	5.05	51.29	4.0
80°		74.69	5.27	56.69	4.2

LOW TEMP HEATING

LOW TEMP HEATING					
Extended Range Option Required Antifreeze Required					
Temp	Temp	Capacity	Power	Heat	COP
25°	60°	45.40	3.92	32.01	3.4
30°		48.83	4.03	35.08	3.6
40°		55.68	4.24	41.22	3.9
25°	70°	42.95	3.99	29.32	3.2
30°		46.19	4.10	32.20	3.3
40°		52.66	4.31	37.95	3.6
25°	80°	40.08	4.08	26.15	2.9
30°		43.09	4.19	28.80	3.0
40°		49.11	4.40	34.08	3.3

Units are complete packages featuring 2 stage operation and containing compressors, reversing valve, expansion valve metering devices, and heat exchangers. Also included are safety controls: Overload protection for motors, high and low refrigerant pressure switches and a solid state lock-out circuit.

Extended range option includes insulated water coils.

Performance based on ARI/ISO rated air flow, fluid flow and voltage. For conditions other than rated, consult the FHP EAD selection software. Due to variations in installation actual performance may vary marginally from tabulated values.

As a result of continuing research and development, specifications are subject to change without notice.
EM072ip6 mod2 Rev: 6-02

FHP MANUFACTURING COMPANY

601 N.W. 65th Court - Fort Lauderdale, FL 33309

Phone: (954) 776-5471 - Fax: (800) 776-5529

<http://www.fhp-mfg.com>



2 STAGE PACKAGED UNITS SPECIFICATION DATA SHEET

FHP MANUFACTURING HIGH-EFFICIENCY WATER SOURCE HEAT PUMPS

EM096

ENERGY-MISER

ELECTRICAL SPECIFICATIONS

Electrical Characteristics	Elect. Symbol	Compressor (x2)		Blower		Loop Pump		Min. Circuit Amps*	Max. Fuse/Breaker
		RLA	LRA	FLA*	HP*	FLA	HP		
208/230-1-60	-1	20.5	115.0	10.2/12.3	1-1/2 / 2	-	-	56.3/58.4	70
208/230-3-60	-3	12.4	90.0	5.0/6.4	1-1/2 / 2	-	-	32.9/34.3	45
460-3-60	-4	6.4	44.0	2.5/3.2	1-1/2 / 2	-	-	16.9/17.6	20
575-3-60	-5	4.8	34.0	2.0/2.0	1-1/2 / 2	-	-	12.8/12.8	15

*Vertical units use one 1-1/2 HP motor (first value) while horizontal units use one 2 HP motor (second value)

MECHANICAL SPECIFICATIONS

Refrigerant: R-22			
Air Coil			
Square Feet	Rows Deep	Tube O.D.	Fins/Inch
9.00	3	3/8	14
Water Coil			
Type	Work Press		
Coaxial	450 psig		
Blower Size	Compr Type		
12x12 BD	Scroll		
Net Weight	Ship Weight		
679 lbs	704 lbs		

BLOWER PERFORMANCE

Available External Static Pressure (Inches of Water, Gauge. Wet Coil and Filter Included)												
Motor Sheave	0.10	0.20	0.30	0.40	0.50	0.60	0.70	0.80	0.90	1.00	1.10	1.20
Closed	-	-	-	-	-	-	-	2800	2650	2450	2300	2200
1/2 Open	-	-	3480	3340	3230	3075	2880	2690	2555	2355	-	-
Open	3110	2965	2835	2615	2460	2275	-	-	-	-	-	-



ISO 13256-1 CERTIFIED PERFORMANCE DATA Rated at 2,800 CFM and 21.0 GPM

Water Loop				Ground Water				Ground Loop (Ext. Range Required)			
Cooling		Heating		Cooling		Heating		Cooling		Heating	
Capacity	EER	Capacity	COP	Capacity	EER	Capacity	COP	Capacity	EER	Capacity	COP
95,000	13.2	106,000	4.7	100,000	18.0	85,000	4.1	96,000	15.0	66,000	3.5

FLUID PRESSURE DROP

Fluid Flow (GPM)	Pressure Drop	
	(FOH)	(PSIG)
12	5.7	2.4
14	7.5	3.2
18	11.7	5.1
21	15.5	6.7
24	19.7	8.5

CAPACITY DATA All performance at 2,800CFM and 21.0 GPM

COOLING							
EFT Range (Standard) 50°F to 100°F				EFT Range (Ext. Range Option) 45°F to 110°F			
Entering Fluid Temp. (°F)	Entering Air Temp. (°F)	Total Capacity (MBtuH)	Sensible Capacity (MBtuH)	Sensible to Total Ratio	Power Input (kW)	Heat of Reject (MBtuH)	EER
50°	70°db	86.19	56.93	0.66	5.00	103.24	17.2
60°		84.68	56.41	0.67	5.57	103.68	15.2
70°		83.18	56.11	0.67	6.14	104.13	13.6
85°		80.92	56.04	0.69	6.99	104.79	11.6
100°		78.67	56.40	0.72	7.85	105.45	10.0
50°	75°db	92.35	68.07	0.74	5.02	109.50	18.4
60°		90.74	67.45	0.74	5.60	109.85	16.2
70°		89.13	67.09	0.75	6.17	110.19	14.4
85°		86.72	67.01	0.77	7.03	110.72	12.3
100°		84.30	67.43	0.80	7.89	111.24	10.7
50°	80°db	101.36	75.15	0.74	5.06	118.65	20.0
60°		99.60	74.47	0.75	5.64	118.85	17.7
70°		97.83	74.07	0.76	6.22	119.06	15.7
85°		95.19	73.99	0.78	7.09	119.38	13.4
100°		92.54	74.45	0.80	7.96	119.69	11.6
50°	85°db	110.38	82.31	0.75	5.10	127.79	21.6
60°		108.46	81.56	0.75	5.69	127.86	19.1
70°		106.54	81.13	0.76	6.27	127.93	17.0
85°		103.66	81.03	0.78	7.14	128.04	14.5
100°		100.78	81.54	0.81	8.02	128.15	12.6

HEATING

HEATING					
EFT Range (Standard) 50°F to 80°F			EFT Range (Ext. Range Option) 25°F to 80°F		
Entering Fluid Temp. (°F)	Entering Air Temp. (°F)	Total Capacity (MBtuH)	Power Input (kW)	Heat of Abs. (MBtuH)	COP
50°	60°	91.30	6.16	70.27	4.3
60°		102.53	6.46	80.49	4.7
70°		113.76	6.76	90.70	4.9
80°		124.98	7.05	100.92	5.2
50°		70°	86.33	6.27	64.92
60°	96.94		6.58	74.50	4.3
70°	107.55		6.88	84.07	4.6
80°	118.15		7.18	93.65	4.8
50°	80°		80.49	6.41	58.61
60°		90.37	6.72	67.44	3.9
70°		100.25	7.03	76.26	4.2
80°		110.13	7.34	85.08	4.4

LOW TEMP HEATING

LOW TEMP HEATING					
Extended Range Option Required Antifreeze Required					
Entering Fluid Temp. (°F)	Entering Air Temp. (°F)	Total Capacity (MBtuH)	Power Input (kW)	Heat of Abs. (MBtuH)	COP
25°	60°	61.99	5.42	43.49	3.4
30°		67.50	5.57	48.49	3.6
40°		78.50	5.87	58.49	3.9
25°	70°	58.64	5.52	39.81	3.1
30°		63.84	5.67	44.49	3.3
40°		74.24	5.97	53.86	3.6
25°	80°	54.70	5.64	35.46	2.8
30°		59.54	5.79	39.78	3.0
40°		69.23	6.10	48.40	3.3

Units are complete packages featuring 2 stage operation and containing compressors, reversing valve, expansion valve metering devices, and heat exchangers. Also included are safety controls: Overload protection for motors, high and low refrigerant pressure switches and a solid state lock-out circuit.

Extended range option includes insulated water coils.

Performance based on ARI/ISO rated air flow, fluid flow and voltage. For conditions other than rated, consult the FHP EAD selection software. Due to variations in installation actual performance may vary marginally from tabulated values.

As a result of continuing research and development, specifications are subject to change without notice.
EM096ip6 mod2 Rev: 6-02

FHP MANUFACTURING COMPANY

601 N.W. 65th Court - Fort Lauderdale, FL 33309

Phone: (954) 776-5471 - Fax: (800) 776-5529

<http://www.fhp-mfg.com>



2 STAGE PACKAGED UNITS SPECIFICATION DATA SHEET

FHP MANUFACTURING HIGH-EFFICIENCY WATER SOURCE HEAT PUMPS

EM120

ENERGY-MISER

ELECTRICAL SPECIFICATIONS

Electrical Characteristics	Elect. Symbol	Compressor (x2)		Blower		Loop Pump		Min. Circuit Amps*	Max. Fuse/ Breaker
		RLA	LRA	FLA*	HP*	FLA	HP		
208/230-1-60	-1	27.9	170.0	12.3	2	-	-	75.1	100
208/230-3-60	-3	17.3	123.0	6.4/9.0	2 / 3	-	-	45.3/47.9	60
460-3-60	-4	7.1	49.5	3.2/4.5	2 / 3	-	-	19.2/20.5	25
575-3-60	-5	5.8	40.0	2.0/3.7	2 / 3	-	-	15.1/16.8	20

*Vertical units use one 2 HP motor (first value) while horizontal units use one 3 HP motor & 2 12x9 blowers (second value)

MECHANICAL SPECIFICATIONS

Refrigerant: R-22			
Air Coil			
Square Feet	Rows Deep	Tube O.D.	Fins/Inch
9.00	3	3/8	14
Water Coil			
Type	Work Press		
Coaxial	450 psig		
Blower Size*	Compr Type		
15x15 BD	Scroll		
Net Weight	Ship Weight		
875 lbs	900 lbs		

BLOWER PERFORMANCE

Available External Static Pressure (Inches of Water, Gauge. Wet Coil and Filter Included)												
Motor Sheave	0.10	0.20	0.30	0.40	0.50	0.60	0.70	0.80	0.90	1.00	1.10	1.20
Closed	-	-	-	-	-	-	-	-	4400	4150	3830	3600
1/2 Open	-	-	-	4660	4490	4240	3950	3600	3000	-	-	-
Open	4680	4490	4270	4000	3700	3370	-	-	-	-	-	-



ISO 13256-1 CERTIFIED PERFORMANCE DATA Rated at 4,000 CFM and 28.0 GPM

Water Loop				Ground Water				Ground Loop (Ext. Range Required)			
Cooling		Heating		Cooling		Heating		Cooling		Heating	
Capacity	EER	Capacity	COP	Capacity	EER	Capacity	COP	Capacity	EER	Capacity	COP
120,000	13.4	142,000	5.0	135,000	18.0	112,000	4.3	124,000	16.2	92,000	3.6

FLUID PRESSURE DROP

Fluid Flow (GPM)	Pressure Drop	
	(FOH)	(PSIG)
16	4.8	2.1
20	7.2	3.1
24	10.0	4.3
28	13.2	5.7
32	16.8	7.3

CAPACITY DATA All performance at 4,000CFM and 28.0 GPM

COOLING							
EFT Range (Standard) 50°F to 100°F				EFT Range (Ext. Range Option) 45°F to 110°F			
Entering Fluid Temp. (°F)	Entering Air Temp. (°F)	Total Capacity (MBtuH)	Sensible Capacity (MBtuH)	Sensible to Total Ratio	Power Input (kW)	Heat of Reject (MBtuH)	EER
50°	70°db	118.42	78.11	0.66	7.03	142.42	16.8
60°		113.78	75.67	0.67	7.47	139.26	15.2
70°		109.13	73.48	0.67	7.90	136.09	13.8
85°		102.16	70.60	0.69	8.55	131.34	11.9
100°		95.19	68.09	0.72	9.20	126.60	10.3
50°	75°db	126.91	93.46	0.74	7.07	151.05	17.9
60°		121.94	90.54	0.74	7.51	147.56	16.2
70°		116.97	87.94	0.75	7.94	144.08	14.7
85°		109.50	84.51	0.77	8.60	138.85	12.7
100°		102.04	81.52	0.80	9.25	133.63	11.0
50°	80°db	139.34	103.22	0.74	7.12	163.65	19.6
60°		133.88	100.01	0.75	7.56	159.70	17.7
70°		128.43	97.14	0.76	8.01	155.75	16.0
85°		120.25	93.36	0.78	8.67	149.82	13.9
100°		112.07	90.06	0.80	9.33	143.90	12.0
50°	85°db	151.76	113.08	0.75	7.18	176.26	21.1
60°		145.82	109.57	0.75	7.62	171.84	19.1
70°		139.89	106.43	0.76	8.07	167.42	17.3
85°		130.99	102.29	0.78	8.73	160.80	15.0
100°		122.10	98.68	0.81	9.40	154.17	13.0

HEATING

HEATING					
EFT Range (Standard) 50°F to 80°F			EFT Range (Ext. Range Option) 25°F to 80°F		
Entering Fluid Temp. (°F)	Entering Air Temp. (°F)	Total Capacity (MBtuH)	Power Input (kW)	Heat of Abs. (MBtuH)	COP
50°	60°	123.35	8.10	95.71	4.5
60°		137.33	8.33	108.92	4.8
70°		151.32	8.55	122.12	5.2
80°		165.31	8.78	135.33	5.5
50°		70°	116.65	8.24	88.53
60°	129.87		8.47	100.94	4.5
70°	143.08		8.71	113.36	4.8
80°	156.29		8.94	125.78	5.1
50°	80°		108.79	8.42	80.06
60°		121.09	8.66	91.55	4.1
70°		133.40	8.90	103.04	4.4
80°		145.70	9.13	114.53	4.7

LOW TEMP HEATING

LOW TEMP HEATING					
Extended Range Option Required Antifreeze Required					
Temp	Temp	Capacity	Power	Heat	COP
25°	60°	86.65	7.53	60.97	3.4
30°		93.51	7.64	67.43	3.6
40°		107.22	7.87	80.36	4.0
25°	70°	81.98	7.66	55.84	3.1
30°		88.46	7.78	61.92	3.3
40°		101.41	8.01	74.08	3.7
25°	80°	76.49	7.82	49.80	2.9
30°		82.53	7.94	55.42	3.0
40°		94.59	8.18	66.67	3.4

Units are complete packages featuring 2 stage operation and containing compressors, reversing valve, expansion valve metering devices, and heat exchangers. Also included are safety controls: Overload protection for motors, high and low refrigerant pressure switches and a solid state lock-out circuit.

Extended range option includes insulated water coils.

Performance based on ARI/ISO rated air flow, fluid flow and voltage. For conditions other than rated, consult the FHP EAD selection software. Due to variations in installation actual performance may vary marginally from tabulated values.

As a result of continuing research and development, specifications are subject to change without notice.
EM120ip6 mod2 Rev: 6-02

FHP MANUFACTURING COMPANY
601 N.W. 65th Court - Fort Lauderdale, FL 33309
Phone: (954) 776-5471 - Fax: (800) 776-5529
<http://www.fhp-mfg.com>



2 STAGE HORIZONTAL PACKAGED UNITS SPECIFICATION DATA SHEET

FHP MANUFACTURING HIGH-EFFICIENCY WATER SOURCE HEAT PUMPS

EM140

ENERGY-MISER

ELECTRICAL SPECIFICATIONS

Electrical Characteristics	Elect. Symbol	Compressor (x2)		Blower		Loop Pump		Min. Circuit Amps	Max. Fuse/Breaker
		RLA	LRA	FLA	HP	FLA	HP		
208/230-3-60	-3	19.1	123.0	9.0	3	-	-	52.0	70
460-3-60	-4	9.1	62.0	4.5	3	-	-	25.0	30
575-3-60	-5	7.2	50.0	3.7	3	-	-	19.9	25

MECHANICAL SPECIFICATIONS

Refrigerant: R-22			
Air Coil			
Square Feet	Rows Deep	Tube O.D.	Fins/Inch
10.83	3	3/8	14
Water Coil			
Type	Work Press		
Coaxial	450 psig		
Blower Size	Compr Type		
15x15 BD	Scroll		
Net Weight	Ship Weight		
880 lbs	910 lbs		

BLOWER PERFORMANCE

Available External Static Pressure (Inches of Water, Gauge. Wet Coil and Filter Included)												
Motor Sheave	0.10	0.20	0.30	0.40	0.50	0.60	0.70	0.80	0.90	1.00	1.10	1.20
Closed	-	-	-	-	-	-	-	-	5300	5020	4750	4410
1/2 Open	-	-	-	5280	5080	4850	4610	4350	4050	3680	-	-
Open	5050	4820	4580	4300	4000	3680	-	-	-	-	-	-



FLUID PRESSURE DROP

Fluid Flow (GPM)	Pressure Drop	
	(FOH)	(PSIG)
20	3.4	1.5
25	5.1	2.2
30	7.0	3.0
35	9.3	4.0
45	14.6	6.3

RATED IN ACCORDANCE WITH ISO 13256-1 Rated at 5,000 CFM and 35.0 GPM

Water Loop				Ground Water				Ground Loop (Ext. Range Required)			
Cooling		Heating		Cooling		Heating		Cooling		Heating	
Capacity	EER	Capacity	COP	Capacity	EER	Capacity	COP	Capacity	EER	Capacity	COP
140,000	11.5	174,000	4.2	162,000	15.6	142,000	3.9	143,000	12.3	104,000	3.2

CAPACITY DATA All performance at 5,000CFM and 35.0 GPM

COOLING <small>EFT Range 45°F to 110°F</small>							
Entering Fluid Temp. (°F)	Entering Air Temp. (°F)	Total Capacity (MBtuH)	Sensible Capacity (MBtuH)	Sensible to Total Ratio	Power Input (kW)	Heat of Reject (MBtuH)	EER
50°	70°db 61°wb	141.60	93.03	0.66	10.53	177.56	13.4
60°		134.50	89.07	0.66	11.19	172.70	12.0
70°		127.40	85.41	0.67	11.85	167.84	10.8
85°		116.75	80.32	0.69	12.83	160.55	9.1
100°		106.10	75.53	0.71	13.82	153.27	7.7
50°	75°db 63°wb	151.83	111.52	0.73	10.59	187.98	14.3
60°		144.23	106.81	0.74	11.25	182.64	12.8
70°		136.63	102.44	0.75	11.91	177.29	11.5
85°		125.23	96.37	0.77	12.90	169.28	9.7
100°		113.83	90.68	0.80	13.90	161.26	8.2
50°	80°db 67°wb	166.80	123.28	0.74	10.67	203.22	15.6
60°		158.47	118.09	0.75	11.34	197.16	14.0
70°		150.14	113.27	0.75	12.00	191.11	12.5
85°		137.64	106.59	0.77	13.00	182.02	10.6
100°		125.14	100.31	0.80	14.00	172.94	8.9
50°	85°db 71°wb	181.77	135.16	0.74	10.75	218.46	16.9
60°		172.70	129.48	0.75	11.42	211.69	15.1
70°		163.64	124.22	0.76	12.09	204.92	13.5
85°		150.05	116.91	0.78	13.10	194.77	11.5
100°		136.45	110.04	0.81	14.11	184.61	9.7

HEATING <small>EFT Range 25°F to 80°F</small>					
Entering Fluid Temp. (°F)	Entering Air Temp. (°F)	Total Capacity (MBtuH)	Power Input (kW)	Heat of Abs. (MBtuH)	COP
50°	60°	150.76	11.49	111.53	3.8
60°		170.48	12.21	128.81	4.1
70°		190.21	12.93	146.09	4.3
80°		209.93	13.64	163.37	4.5
50°		70°	142.63	11.69	102.72
60°	161.27		12.42	118.86	3.8
70°	179.90		13.15	135.01	4.0
80°	198.53		13.88	151.15	4.2
50°	80°		133.09	11.94	92.33
60°		150.44	12.69	107.14	3.5
70°		167.80	13.44	121.94	3.7
80°		185.15	14.18	136.75	3.8

LOW TEMP HEATING <small>Antifreeze Required</small>					
Entering Fluid Temp. (°F)	Entering Air Temp. (°F)	Total Capacity (MBtuH)	Power Input (kW)	Heat of Abs. (MBtuH)	COP
25°	60°	99.46	9.70	66.34	3.0
30°		109.13	10.06	74.79	3.2
40°		128.47	10.78	91.68	3.5
25°	70°	94.17	9.87	60.48	2.8
30°		103.30	10.23	68.37	3.0
40°		121.57	10.96	84.15	3.2
25°	80°	87.94	10.07	53.56	2.6
30°		96.45	10.45	60.79	2.7
40°		113.46	11.19	75.26	3.0

Units are complete packages featuring 2 stage operation and containing compressors, reversing valve, expansion valve metering devices, and heat exchangers. Also included are safety controls: Overload protection for motors, high and low refrigerant pressure switches and a solid state lock-out circuit.

Performance based on ARI/ISO rated air flow, fluid flow and voltage. For conditions other than rated, consult the FHP EAD selection software. Due to variations in installation actual performance may vary marginally from tabulated values.



2 STAGE VERTICAL PACKAGED UNITS SPECIFICATION DATA SHEET

FHP MANUFACTURING HIGH-EFFICIENCY WATER SOURCE HEAT PUMPS

EM144

ENERGY-MISER

ELECTRICAL SPECIFICATIONS

Electrical Characteristics	Elect. Symbol	Compressor (x2)		Blower (x2)		Loop Pump		Min. Circuit Amps	Max. Fuse/Breaker
		RLA	LRA	FLA	HP	FLA	HP		
208/230-3-60	-3	19.1	123.0	5.0	1 1/2	-	-	53.0	70
460-3-60	-4	9.1	62.0	2.5	1 1/2	-	-	25.5	35
575-3-60	-5	7.2	50.0	2.0	1 1/2	-	-	20.2	25

MECHANICAL SPECIFICATIONS

Refrigerant: R-22			
Air Coil			
Square Feet	Rows Deep	Tube O.D.	Fins/Inch
14.00	3	3/8	14
Water Coil			
Type	Work Press		
Coaxial	450 psig		
Blower Size	Compr Type		
12x12 BD	Scroll		
Net Weight	Ship Weight		
1,050 lbs	1,140 lbs		

BLOWER PERFORMANCE

Available External Static Pressure (Inches of Water, Gauge. Wet Coil and Filter Included)												
Motor Sheave	0.10	0.20	0.30	0.40	0.50	0.60	0.70	0.80	0.90	1.00	1.10	1.20
Closed	-	-	-	-	-	-	7120	6920	6530	6080	5660	5120
1/2 Open	-	-	-	6860	6530	6120	5780	5380	4880	4090	-	-
Open	6770	6300	5880	5430	4970	4340	3750	-	-	-	-	-



FLUID PRESSURE DROP

Fluid Flow (GPM)	Pressure Drop	
	(FOH)	(PSIG)
20	3.4	1.5
25	5.1	2.2
30	7.0	3.0
35	9.3	4.0
50	17.6	7.6

RATED IN ACCORDANCE WITH ISO 13256-1 Rated at 5,000 CFM and 35.0 GPM

Water Loop				Ground Water				Ground Loop (Ext. Range Required)			
Cooling		Heating		Cooling		Heating		Cooling		Heating	
Capacity	EER	Capacity	COP	Capacity	EER	Capacity	COP	Capacity	EER	Capacity	COP
150,000	15.3	173,000	5.5	177,000	23.1	138,000	4.9	156,000	17.1	100,000	4.1

CAPACITY DATA All performance at 5,000 CFM and 35.0 GPM

COOLING							
EFT Range (Standard) 50°F to 100°F				EFT Range (Ext. Range Option) 45°F to 110°F			
Entering Fluid Temp. (°F)	Entering Air Temp. (°F)	Total Capacity (MBtuH)	Sensible Capacity (MBtuH)	Sensible to Total Ratio	Power Input (kW)	Heat of Reject (MBtuH)	EER
50°		153.77	100.35	0.65	8.42	182.52	18.3
60°	70°db	145.19	95.48	0.66	9.21	176.62	15.8
70°	61°wb	136.61	90.92	0.67	9.99	170.71	13.7
85°		123.74	84.48	0.68	11.17	161.86	11.1
100°		110.87	78.32	0.71	12.35	153.01	9.0
50°		165.03	120.68	0.73	8.46	193.91	19.5
60°	75°db	155.84	114.89	0.74	9.25	187.42	16.8
70°	63°wb	146.66	109.45	0.75	10.04	180.93	14.6
85°		132.88	101.78	0.77	11.23	171.19	11.8
100°		119.10	94.45	0.79	12.41	161.46	9.6
50°		181.49	133.62	0.74	8.52	210.56	21.3
60°	80°db	171.42	127.23	0.74	9.31	203.21	18.4
70°	67°wb	161.35	121.24	0.75	10.11	195.86	16.0
85°		146.25	112.79	0.77	11.31	184.83	12.9
100°		131.14	104.70	0.80	12.50	173.80	10.5
50°		197.95	146.69	0.74	8.57	227.22	23.1
60°	85°db	187.00	139.70	0.75	9.38	219.00	19.9
70°	71°wb	176.04	133.15	0.76	10.18	210.79	17.3
85°		159.61	123.91	0.78	11.38	198.47	14.0
100°		143.18	115.06	0.80	12.59	186.15	11.4

HEATING					
EFT Range (Standard) 50°F to 80°F			EFT Range (Ext. Range Option) 25°F to 80°F		
Entering Fluid Temp. (°F)	Entering Air Temp. (°F)	Total Capacity (MBtuH)	Power Input (kW)	Heat of Abs. (MBtuH)	COP
50°		149.92	9.64	117.01	4.6
60°	60°	170.54	10.21	135.69	4.9
70°		191.15	10.78	154.37	5.2
80°		211.77	11.34	173.05	5.5
50°		141.97	9.80	108.54	4.2
60°	70°	161.45	10.37	126.04	4.6
70°		180.92	10.95	143.55	4.8
80°		200.40	11.53	161.05	5.1
50°		132.63	9.98	98.56	3.9
60°	80°	150.77	10.57	114.68	4.2
70°		168.91	11.16	130.80	4.4
80°		187.05	11.76	146.93	4.7

LOW TEMP HEATING					
Extended Range Option Required Antifreeze Required					
Temp	Temp	Capacity	Power	Heat	COP
25°		96.45	8.23	68.37	3.4
30°	60°	106.56	8.51	77.51	3.7
40°		126.77	9.08	95.79	4.1
25°		91.45	8.35	62.94	3.2
30°	70°	101.00	8.64	71.51	3.4
40°		120.09	9.22	88.63	3.8
25°		85.58	8.51	56.54	2.9
30°	80°	94.47	8.80	64.43	3.1
40°		112.25	9.39	80.19	3.5

Units are complete packages featuring 2 stage operation and containing compressors, reversing valve, expansion valve metering devices, and heat exchangers. Also included are safety controls: Overload protection for motors, high and low refrigerant pressure switches and a solid state lock-out circuit.

Extended range option includes insulated water coils.

Performance based on ARI/ISO rated air flow, fluid flow and voltage. For conditions other than rated, consult the FHP EAD selection software. Due to variations in installation actual performance may vary marginally from tabulated values.

As a result of continuing research and development, specifications are subject to change without notice.
EM144ip6 mod2 Rev: 7-02

FHP MANUFACTURING COMPANY
601 N.W. 65th Court - Fort Lauderdale, FL 33309
Phone: (954) 776-5471 - Fax: (800) 776-5529
<http://www.fhp-mfg.com>



2 STAGE VERTICAL PACKAGED UNITS SPECIFICATION DATA SHEET

FHP MANUFACTURING HIGH-EFFICIENCY WATER SOURCE HEAT PUMPS

EM168

ENERGY-MISER

ELECTRICAL SPECIFICATIONS

Electrical Characteristics	Elect. Symbol	Compressor (x2)		Blower (x2)		Loop Pump		Min. Circuit Amps	Max. Fuse/Breaker
		RLA	LRA	FLA	HP	FLA	HP		
208/230-3-60	-3	21.8	158.0	6.4	2	-	-	61.9	80
460-3-60	-4	10.3	79.0	3.2	2	-	-	29.6	40
575-3-60	-5	9.0	65.0	2.0	2	-	-	24.3	30

MECHANICAL SPECIFICATIONS

Refrigerant: R-22			
Air Coil			
Square Feet	Rows Deep	Tube O.D.	Fins/Inch
14.00	3	3/8	14
Water Coil			
Type	Work Press		
Coaxial	450 psig		
Blower Size	Compr Type		
12x12 BD	Scroll		
Net Weight	Ship Weight		
1,090 lbs	1,180 lbs		

BLOWER PERFORMANCE

Available External Static Pressure (Inches of Water, Gauge. Wet Coil and Filter Included)												
Motor Sheave	0.10	0.20	0.30	0.40	0.50	0.60	0.70	0.80	0.90	1.00	1.10	1.20
Closed	-	-	-	-	-	-	7200	6940	6560	6150	5710	5140
1/2 Open	-	-	7200	6930	6580	6200	5800	5450	4920	-	-	-
Open	6780	6350	5970	5540	5050	4510	-	-	-	-	-	-



FLUID PRESSURE DROP

Fluid Flow (GPM)	Pressure Drop	
	(FOH)	(PSIG)
22	4.0	1.7
27	5.8	2.5
32	7.9	3.4
42	12.9	5.6
52	18.9	8.2

RATED IN ACCORDANCE WITH ISO 13256-1 Rated at 6,000 CFM and 42.0 GPM

Water Loop				Ground Water				Ground Loop (Ext. Range Required)			
Cooling		Heating		Cooling		Heating		Cooling		Heating	
Capacity	EER	Capacity	COP	Capacity	EER	Capacity	COP	Capacity	EER	Capacity	COP
174,000	13.6	196,000	4.8	188,000	19.2	150,000	4.1	175,000	14.7	112,000	3.4

CAPACITY DATA All performance at 6,000 CFM and 42.0 GPM

COOLING							
EFT Range (Standard) 50°F to 100°F				EFT Range (Ext. Range Option) 45°F to 110°F			
Entering Fluid Temp. (°F)	Entering Air Temp. (°F)	Total Capacity (MBtuH)	Sensible Capacity (MBtuH)	Sensible to Total Ratio	Power Input (kW)	Heat of Reject (MBtuH)	EER
50°	70°db	160.30	104.96	0.65	9.87	194.00	16.2
60°		155.84	102.89	0.66	10.98	193.32	14.2
70°		151.39	101.22	0.67	12.08	192.63	12.5
85°		144.70	99.34	0.69	13.74	191.60	10.5
100°		138.01	98.13	0.71	15.40	190.57	9.0
50°	75°db	171.96	126.03	0.73	9.92	205.83	17.3
60°		167.19	123.57	0.74	11.04	204.85	15.1
70°		162.41	121.56	0.75	12.15	203.87	13.4
85°		155.26	119.33	0.77	13.81	202.41	11.2
100°		148.10	117.89	0.80	15.48	200.94	9.6
50°	80°db	189.01	139.43	0.74	9.99	223.12	18.9
60°		183.78	136.71	0.74	11.12	221.72	16.5
70°		178.55	134.51	0.75	12.24	220.31	14.6
85°		170.70	132.05	0.77	13.92	218.20	12.3
100°		162.85	130.46	0.80	15.60	216.09	10.4
50°	85°db	206.06	152.96	0.74	10.07	240.42	20.5
60°		200.37	149.99	0.75	11.20	238.58	17.9
70°		194.68	147.58	0.76	12.33	236.75	15.8
85°		186.15	144.89	0.78	14.02	234.00	13.3
100°		177.61	143.16	0.81	15.72	231.25	11.3

HEATING					
EFT Range (Standard) 50°F to 80°F			EFT Range (Ext. Range Option) 25°F to 80°F		
Entering Fluid Temp. (°F)	Entering Air Temp. (°F)	Total Capacity (MBtuH)	Power Input (kW)	Heat of Abs. (MBtuH)	COP
50°	60°	164.54	11.91	123.90	4.0
60°		188.07	12.54	145.27	4.4
70°		211.60	13.17	166.65	4.7
80°		235.14	13.81	188.02	5.0
50°		70°	155.74	12.11	114.42
60°	177.97		12.75	134.45	4.1
70°	200.20		13.40	154.48	4.4
80°	222.43		14.04	174.51	4.6
50°	80°		145.40	12.35	103.24
60°		166.10	13.01	121.69	3.7
70°		186.81	13.67	140.14	4.0
80°		207.51	14.33	158.59	4.2

LOW TEMP HEATING					
Extended Range Option Required Antifreeze Required					
Temp	Temp	Capacity	Power	Heat	COP
25°	60°	103.64	10.33	68.39	2.9
30°		115.17	10.64	78.85	3.2
40°		138.24	11.28	99.76	3.6
25°	70°	98.19	10.50	62.37	2.7
30°		109.09	10.82	72.17	3.0
40°		130.89	11.46	91.77	3.3
25°	80°	91.80	10.70	55.27	2.5
30°		101.95	11.03	64.29	2.7
40°		122.25	11.69	82.34	3.1

Units are complete packages featuring 2 stage operation and containing compressors, reversing valve, expansion valve metering devices, and heat exchangers. Also included are safety controls: Overload protection for motors, high and low refrigerant pressure switches and a solid state lock-out circuit.

Extended range option includes insulated water coils.

Performance based on ARI/ISO rated air flow, fluid flow and voltage. For conditions other than rated, consult the FHP EAD selection software. Due to variations in installation actual performance may vary marginally from tabulated values.

As a result of continuing research and development, specifications are subject to change without notice.
EM168ip6 mod2 Rev: 7-02

FHP MANUFACTURING COMPANY
601 N.W. 65th Court - Fort Lauderdale, FL 33309
Phone: (954) 776-5471 - Fax: (800) 776-5529
<http://www.fhp-mfg.com>



2 STAGE HORIZONTAL PACKAGED UNITS SPECIFICATION DATA SHEET

FHP MANUFACTURING HIGH-EFFICIENCY WATER SOURCE HEAT PUMPS

EM170

ENERGY-MISER

ELECTRICAL SPECIFICATIONS

Electrical Characteristics	Elect. Symbol	Compressor (x2)		Blower (x2)		Loop Pump		Min. Circuit Amps	Max. Fuse/Breaker
		RLA	LRA	FLA	HP	FLA	HP		
208/230-3-60	-3	21.8	158.0	6.4	2	-	-	61.9	80
460-3-60	-4	10.3	79.0	3.2	2	-	-	29.6	40
575-3-60	-5	9.0	65.0	2.0	2	-	-	24.3	30

MECHANICAL SPECIFICATIONS

Refrigerant: R-22			
Air Coil			
Square Feet	Rows Deep	Tube O.D.	Fins/Inch
11.00	3	3/8	14
Water Coil			
Type	Work Press		
Coaxial	450 psig		
Blower Size	Compr Type		
12x12 BD	Scroll		
Net Weight	Ship Weight		
1,520 lbs	1,620 lbs		

BLOWER PERFORMANCE

Available External Static Pressure (Inches of Water, Gauge. Wet Coil and Filter Included)												
Motor Sheave	0.10	0.20	0.30	0.40	0.50	0.60	0.70	0.80	0.90	1.00	1.10	1.20
Closed	-	-	-	-	-	-	-	-	5960	5850	5410	4940
1/2 Open	-	-	-	-	-	6000	5590	5160	4670	-	-	-
Open	-	6050	5770	5340	4850	4310	-	-	-	-	-	-



FLUID PRESSURE DROP

Fluid Flow (GPM)	Pressure Drop	
	(FOH)	(PSIG)
22	4.0	1.7
27	5.8	2.5
32	7.9	3.4
42	12.9	5.6
52	18.9	8.2

RATED IN ACCORDANCE WITH ISO 13256-1 Rated at 6,000 CFM and 42.0 GPM

Water Loop				Ground Water				Ground Loop (Ext. Range Required)			
Cooling		Heating		Cooling		Heating		Cooling		Heating	
Capacity	EER	Capacity	COP	Capacity	EER	Capacity	COP	Capacity	EER	Capacity	COP
174,000	13.6	196,000	4.8	188,000	19.2	150,000	4.1	175,000	14.7	112,000	3.4

CAPACITY DATA All performance at 6,000 CFM and 42.0 GPM

COOLING							
EFT Range (Standard) 50°F to 100°F				EFT Range (Ext. Range Option) 45°F to 110°F			
Entering Fluid Temp. (°F)	Entering Air Temp. (°F)	Total Capacity (MBtuH)	Sensible Capacity (MBtuH)	Sensible to Total Ratio	Power Input (kW)	Heat of Reject (MBtuH)	EER
50°	70°db	159.59	100.66	0.63	10.08	194.00	15.8
60°		154.96	98.55	0.64	11.25	193.34	13.8
70°		150.33	96.81	0.64	12.41	192.68	12.1
85°		143.38	94.81	0.66	14.16	191.70	10.1
100°		136.44	93.42	0.68	15.90	190.71	8.6
50°	75°db	171.17	120.83	0.71	10.13	205.75	16.9
60°		166.21	118.32	0.71	11.31	204.79	14.7
70°		161.25	116.24	0.72	12.48	203.83	12.9
85°		153.82	113.86	0.74	14.23	202.40	10.8
100°		146.38	112.21	0.77	15.99	200.96	9.2
50°	80°db	188.10	133.66	0.71	10.21	222.94	18.4
60°		182.67	130.89	0.72	11.39	221.54	16.0
70°		177.24	128.60	0.73	12.57	220.13	14.1
85°		169.09	125.97	0.75	14.34	218.03	11.8
100°		160.94	124.15	0.77	16.11	215.92	10.0
50°	85°db	205.04	146.62	0.72	10.28	240.13	19.9
60°		199.13	143.59	0.72	11.47	238.28	17.4
70°		193.22	141.09	0.73	12.66	236.43	15.3
85°		184.35	138.21	0.75	14.45	233.66	12.8
100°		175.49	136.22	0.78	16.23	230.89	10.8

HEATING

HEATING					
EFT Range (Standard) 50°F to 80°F			EFT Range (Ext. Range Option) 25°F to 80°F		
Entering Fluid Temp. (°F)	Entering Air Temp. (°F)	Total Capacity (MBtuH)	Power Input (kW)	Heat of Abs. (MBtuH)	COP
50°	60°	165.50	12.04	124.42	4.0
60°		189.34	12.71	145.97	4.4
70°		213.19	13.38	167.52	4.7
80°		237.03	14.05	189.07	4.9
50°		70°	156.62	12.24	114.84
60°	179.15		12.93	135.03	4.1
70°	201.68		13.61	155.22	4.3
80°	224.21		14.30	175.41	4.6
50°	80°		146.19	12.49	103.55
60°		167.17	13.19	122.14	3.7
70°		188.15	13.89	140.73	4.0
80°		209.13	14.60	159.32	4.2

LOW TEMP HEATING

LOW TEMP HEATING					
			Extended Range Option Required Antifreeze Required		
Temp	Temp	Capacity	Power	Heat	COP
25°	60°	103.81	10.36	68.46	2.9
30°		115.50	10.69	79.00	3.2
40°		138.87	11.36	100.09	3.6
25°	70°	98.33	10.53	62.40	2.7
30°		109.38	10.87	72.27	2.9
40°		131.46	11.56	92.02	3.3
25°	80°	91.90	10.74	55.24	2.5
30°		102.19	11.09	64.33	2.7
40°		122.76	11.79	82.51	3.1

Units are complete packages featuring 2 stage operation and containing compressors, reversing valve, expansion valve metering devices, and heat exchangers. Also included are safety controls: Overload protection for motors, high and low refrigerant pressure switches and a solid state lock-out circuit.

Extended range option includes insulated water coils.

Performance based on ARI/ISO rated air flow, fluid flow and voltage. For conditions other than rated, consult the FHP EAD selection software. Due to variations in installation actual performance may vary marginally from tabulated values.

As a result of continuing research and development, specifications are subject to change without notice.
EM170ip6 mod2 Rev: 7-02

FHP MANUFACTURING COMPANY

601 N.W. 65th Court - Fort Lauderdale, FL 33309

Phone: (954) 776-5471 - Fax: (800) 776-5529

<http://www.fhp-mfg.com>



2 STAGE VERTICAL PACKAGED UNITS SPECIFICATION DATA SHEET

FHP MANUFACTURING HIGH-EFFICIENCY WATER SOURCE HEAT PUMPS

EM210

ENERGY-MISER

ELECTRICAL SPECIFICATIONS

Electrical Characteristics	Elect. Symbol	Compressor (x2)		Blower (x2)		Loop Pump		Min. Circuit Amps	Max. Fuse/Breaker
		RLA	LRA	FLA	HP	FLA	HP		
208/230-3-60	-3	28.8	195.0	5.0	1 1/2	-	-	74.8	100
460-3-60	-4	14.7	85.0	2.5	1 1/2	-	-	38.1	50
575-3-60	-5	8.4	63.0	2.0	1 1/2	-	-	22.9	30

MECHANICAL SPECIFICATIONS

Refrigerant: R-22			
Air Coil			
Square Feet	Rows Deep	Tube O.D.	Fins/Inch
18.10	3	3/8	14
Water Coil			
Type	Work Press		
Coaxial	450 psig		
Blower Size	Compr Type		
15x15 BD	Scroll		
Net Weight	Ship Weight		
1,170 lbs	1,260 lbs		

BLOWER PERFORMANCE

Available External Static Pressure (Inches of Water, Gauge. Wet Coil and Filter Included)												
Motor Sheave	0.10	0.20	0.30	0.40	0.50	0.60	0.70	0.80	0.90	1.00	1.10	1.20
Closed	-	-	-	-	-	-	-	-	-	-	7800	7500
1/2 Open	-	-	-	-	-	8600	8200	7600	6900	5240	-	-
Open	8840	8400	8000	7560	7000	6400	-	-	-	-	-	-



FLUID PRESSURE DROP

Fluid Flow (GPM)	Pressure Drop	
	(FOH)	(PSIG)
30	5.88	2.55
40	9.87	4.27
50	14.75	6.38
60	20.48	8.86
70	27.03	11.70

RATED IN ACCORDANCE WITH ISO 13256-1 Rated at 7,000 CFM and 50.0 GPM

Water Loop				Ground Water				Ground Loop (Ext. Range Required)			
Cooling		Heating		Cooling		Heating		Cooling		Heating	
Capacity	EER	Capacity	COP	Capacity	EER	Capacity	COP	Capacity	EER	Capacity	COP
214,000	14.0	260,000	5.0	282,000	21.7	197,000	4.4	235,000	16.4	145,000	3.8

CAPACITY DATA All performance at 7,000 CFM and 50.0 GPM

COOLING							
EFT Range (Standard) 50°F to 100°F				EFT Range (Ext. Range Option) 45°F to 110°F			
Entering Fluid Temp. (°F)	Entering Air Temp. (°F)	Total Capacity (MBtuH)	Sensible Capacity (MBtuH)	Sensible to Total Ratio	Power Input (kW)	Heat of Reject (MBtuH)	EER
50°	70°db	255.57	167.30	0.65	14.17	303.93	18.0
60°		234.52	154.65	0.66	14.99	285.69	15.6
70°		213.48	142.38	0.67	15.82	267.45	13.5
85°		181.91	124.32	0.68	17.05	240.09	10.7
100°		150.34	106.13	0.71	18.28	212.73	8.2
50°	75°db	274.16	200.90	0.73	14.24	322.77	19.3
60°		251.63	185.83	0.74	15.07	303.06	16.7
70°		229.10	171.22	0.75	15.89	283.35	14.4
85°		195.31	149.70	0.77	17.13	253.79	11.4
100°		161.52	128.04	0.79	18.37	224.23	8.8
50°	80°db	301.36	222.27	0.74	14.34	350.30	21.0
60°		276.66	205.66	0.74	15.17	328.45	18.2
70°		251.96	189.56	0.75	16.01	306.60	15.7
85°		214.92	165.85	0.77	17.26	273.82	12.5
100°		177.88	141.97	0.80	18.51	241.04	9.6
50°	85°db	328.55	243.86	0.74	14.44	377.83	22.8
60°		301.69	225.70	0.75	15.28	353.84	19.8
70°		274.83	208.09	0.76	16.12	329.84	17.1
85°		234.53	182.15	0.78	17.38	293.85	13.5
100°		194.23	156.04	0.80	18.64	257.85	10.4

HEATING

HEATING					
EFT Range (Standard) 50°F to 80°F			EFT Range (Ext. Range Option) 25°F to 80°F		
Entering Fluid Temp. (°F)	Entering Air Temp. (°F)	Total Capacity (MBtuH)	Power Input (kW)	Heat of Abs. (MBtuH)	COP
50°	60°	219.21	14.99	168.03	4.3
60°		251.76	16.10	196.80	4.6
70°		284.32	17.22	225.56	4.8
80°		316.87	18.33	254.32	5.1
50°		70°	207.57	15.24	155.57
60°	238.32		16.37	182.46	4.3
70°	269.07		17.50	209.35	4.5
80°	299.83		18.63	236.24	4.7
50°	80°		193.89	15.53	140.87
60°		222.53	16.69	165.56	3.9
70°		251.17	17.85	190.25	4.1
80°		279.81	19.01	214.94	4.3

LOW TEMP HEATING

LOW TEMP HEATING					
Extended Range Option Required Antifreeze Required					
Entering Fluid Temp. (°F)	Entering Air Temp. (°F)	Total Capacity (MBtuH)	Power Input (kW)	Heat of Abs. (MBtuH)	COP
25°	60°	135.13	12.22	93.42	3.2
30°		151.08	12.77	107.49	3.5
40°		183.00	13.88	135.61	3.9
25°	70°	128.12	12.41	85.77	3.0
30°		143.19	12.97	98.92	3.2
40°		173.34	14.10	125.21	3.6
25°	80°	119.88	12.64	76.75	2.8
30°		133.92	13.22	88.82	3.0
40°		162.00	14.37	112.94	3.3

Units are complete packages featuring 2 stage operation and containing compressors, reversing valve, expansion valve metering devices, and heat exchangers. Also included are safety controls: Overload protection for motors, high and low refrigerant pressure switches and a solid state lock-out circuit.

Extended range option includes insulated water coils.

Performance based on ARI/ISO rated air flow, fluid flow and voltage. For conditions other than rated, consult the FHP EAD selection software. Due to variations in installation actual performance may vary marginally from tabulated values.

As a result of continuing research and development, specifications are subject to change without notice.
EM210ip6 mod2 Rev: 7-06

FHP MANUFACTURING COMPANY

601 N.W. 65th Court - Fort Lauderdale, FL 33309

Phone: (954) 776-5471 - Fax: (800) 776-5529

<http://www.fhp-mfg.com>



2 STAGE VERTICAL PACKAGED UNITS SPECIFICATION DATA SHEET

FHP MANUFACTURING HIGH-EFFICIENCY WATER SOURCE HEAT PUMPS

EM240

ENERGY-MISER

ELECTRICAL SPECIFICATIONS

Electrical Characteristics	Elect. Symbol	Compressor (x2)		Blower (x2)		Loop Pump		Min. Circuit Amps	Max. Fuse/Breaker
		RLA	LRA	FLA	HP	FLA	HP		
208/230-3-60	-3	28.6	179.0	6.4	2	-	-	77.5	100
460-3-60	-4	12.0	90.0	3.2	2	-	-	33.4	45
575-3-60	-5	9.7	72.0	2.0	2	-	-	25.8	35

MECHANICAL SPECIFICATIONS

Refrigerant: R-22			
Air Coil			
Square Feet	Rows Deep	Tube O.D.	Fins/Inch
18.10	3	3/8	14
Water Coil			
Type	Work Press		
Coaxial	450 psig		
Blower Size	Compr Type		
15x15 BD	Scroll		
Net Weight	Ship Weight		
1,250 lbs	1,340 lbs		

BLOWER PERFORMANCE

Available External Static Pressure (Inches of Water, Gauge. Wet Coil and Filter Included)												
Motor Sheave	0.10	0.20	0.30	0.40	0.50	0.60	0.70	0.80	0.90	1.00	1.10	1.20
Closed	-	-	-	-	-	-	-	-	9000	8800	8330	7660
1/2 Open	-	-	-	-	9320	8980	8480	7900	7200	6000	-	-
Open	9360	8980	8540	8000	7400	6740	-	-	-	-	-	-



FLUID PRESSURE DROP

Fluid Flow (GPM)	Pressure Drop	
	(FOH)	(PSIG)
30	3.7	1.6
40	6.2	2.7
50	9.3	4.0
60	12.9	5.6
75	19.2	8.3

RATED IN ACCORDANCE WITH ISO 13256-1 Rated at 8,000 CFM and 60.0 GPM

Water Loop				Ground Water				Ground Loop (Ext. Range Required)			
Cooling		Heating		Cooling		Heating		Cooling		Heating	
Capacity	EER	Capacity	COP	Capacity	EER	Capacity	COP	Capacity	EER	Capacity	COP
240,000	13.8	305,000	4.8	300,000	20.3	240,000	4.4	260,000	15.5	170,000	3.7

CAPACITY DATA All performance at 8,000 CFM and 60.0 GPM

COOLING							
EFT Range (Standard) 50°F to 100°F				EFT Range (Ext. Range Option) 45°F to 110°F			
Entering Fluid Temp. (°F)	Entering Air Temp. (°F)	Total Capacity (MBtuH)	Sensible Capacity (MBtuH)	Sensible to Total Ratio	Power Input (kW)	Heat of Reject (MBtuH)	EER
50°	70°db	268.72	176.01	0.66	15.78	322.58	17.0
60°		250.34	165.22	0.66	16.76	307.53	14.9
70°		231.95	154.90	0.67	17.73	292.47	13.1
85°		204.38	139.96	0.68	19.19	269.89	10.6
100°		176.81	125.19	0.71	20.66	247.30	8.6
50°	75°db	288.25	211.30	0.73	15.86	342.38	18.2
60°		268.57	198.45	0.74	16.84	326.05	15.9
70°		248.89	186.15	0.75	17.82	309.72	14.0
85°		219.38	168.35	0.77	19.29	285.22	11.4
100°		189.86	150.77	0.79	20.76	260.73	9.1
50°	80°db	316.82	233.75	0.74	15.97	371.33	19.8
60°		295.24	219.59	0.74	16.96	353.13	17.4
70°		273.67	206.03	0.75	17.95	334.94	15.2
85°		241.32	186.41	0.77	19.43	307.64	12.4
100°		208.96	167.03	0.80	20.92	280.35	10.0
50°	85°db	345.38	256.42	0.74	16.09	400.28	21.5
60°		321.92	240.93	0.75	17.08	380.22	18.8
70°		298.45	226.11	0.76	18.08	360.15	16.5
85°		263.25	204.66	0.78	19.57	330.06	13.4
100°		228.06	183.46	0.80	21.07	299.96	10.8

HEATING					
EFT Range (Standard) 50°F to 80°F			EFT Range (Ext. Range Option) 25°F to 80°F		
Entering Fluid Temp. (°F)	Entering Air Temp. (°F)	Total Capacity (MBtuH)	Power Input (kW)	Heat of Abs. (MBtuH)	COP
50°	60°	258.92	18.20	196.78	4.2
60°		297.14	19.62	230.19	4.4
70°		335.36	21.03	263.59	4.7
80°		373.58	22.44	297.00	4.9
50°		70°	245.09	18.51	181.92
60°	281.19		19.95	213.12	4.1
70°	317.30		21.38	244.32	4.3
80°	353.41		22.82	275.52	4.5
50°	80°		228.84	18.88	164.40
60°		262.47	20.35	193.01	3.8
70°		296.09	21.82	221.61	4.0
80°		329.72	23.29	250.22	4.1

LOW TEMP HEATING					
Extended Range Option Required Antifreeze Required					
Entering Fluid Temp. (°F)	Entering Air Temp. (°F)	Total Capacity (MBtuH)	Power Input (kW)	Heat of Abs. (MBtuH)	COP
25°	60°	160.16	14.68	110.07	3.2
30°		178.90	15.38	126.40	3.4
40°		216.37	16.79	159.05	3.8
25°	70°	151.78	14.91	100.88	3.0
30°		169.48	15.63	116.13	3.2
40°		204.88	17.07	146.62	3.5
25°	80°	141.93	15.20	90.05	2.7
30°		158.41	15.94	104.02	2.9
40°		191.38	17.41	131.97	3.2

Units are complete packages featuring 2 stage operation and containing compressors, reversing valve, expansion valve metering devices, and heat exchangers. Also included are safety controls: Overload protection for motors, high and low refrigerant pressure switches and a solid state lock-out circuit.

Extended range option includes insulated water coils.

Performance based on ARI/ISO rated air flow, fluid flow and voltage. For conditions other than rated, consult the FHP EAD selection software. Due to variations in installation actual performance may vary marginally from tabulated values.

As a result of continuing research and development, specifications are subject to change without notice.
EM240V/Tip6 mod2 Rev: 7-02

FHP MANUFACTURING COMPANY
601 N.W. 65th Court - Fort Lauderdale, FL 33309
Phone: (954) 776-5471 - Fax: (800) 776-5529
<http://www.fhp-mfg.com>



2 STAGE HORIZONTAL PACKAGED UNITS SPECIFICATION DATA SHEET

FHP MANUFACTURING HIGH-EFFICIENCY WATER SOURCE HEAT PUMPS

EM242

ENERGY-MISER

ELECTRICAL SPECIFICATIONS

Electrical Characteristics	Elect. Symbol	Compressor (x2)		Blower (x2)		Loop Pump		Min. Circuit Amps	Max. Fuse/Breaker
		RLA	LRA	FLA	HP	FLA	HP		
208/230-3-60	-3	28.6	179.0	6.4	2	-	-	77.5	100
460-3-60	-4	12.0	90.0	3.2	2	-	-	33.4	45
575-3-60	-5	9.7	72.0	2.0	2	-	-	25.8	35

MECHANICAL SPECIFICATIONS

Refrigerant: R-22			
Air Coil			
Square Feet	Rows Deep	Tube O.D.	Fins/Inch
15.30	3	3/8	14
Water Coil			
Type	Work Press		
Coaxial	450 psig		
Blower Size	Compr Type		
15x15 BD	Scroll		
Net Weight	Ship Weight		
1,655 lbs	1,755 lbs		

BLOWER PERFORMANCE

Available External Static Pressure (Inches of Water, Gauge. Wet Coil and Filter Included)												
Motor Sheave	0.10	0.20	0.30	0.40	0.50	0.60	0.70	0.80	0.90	1.00	1.10	1.20
Closed	-	-	-	-	-	-	-	-	-	-	8120	7500
1/2 Open	-	-	-	-	-	-	8280	7700	7000	5800	-	-
Open	-	-	8340	7800	7200	6540	-	-	-	-	-	-



RATED IN ACCORDANCE WITH ISO 13256-1 Rated at 8,000 CFM and 60.0 GPM

Water Loop				Ground Water				Ground Loop (Ext. Range Required)			
Cooling		Heating		Cooling		Heating		Cooling		Heating	
Capacity	EER	Capacity	COP	Capacity	EER	Capacity	COP	Capacity	EER	Capacity	COP
240,000	13.8	305,000	4.8	300,000	20.3	240,000	4.4	260,000	15.5	170,000	3.7

FLUID PRESSURE DROP

Fluid Flow (GPM)	Pressure Drop	
	(FOH)	(PSIG)
30	3.7	1.6
40	6.2	2.7
50	9.3	4.0
60	12.9	5.6
75	19.2	8.3

CAPACITY DATA All performance at 8,000 CFM and 60.0 GPM

COOLING							
EFT Range (Standard) 50°F to 100°F				EFT Range (Ext. Range Option) 45°F to 110°F			
Entering Fluid Temp. (°F)	Entering Air Temp. (°F)	Total Capacity (MBtuH)	Sensible Capacity (MBtuH)	Sensible to Total Ratio	Power Input (kW)	Heat of Reject (MBtuH)	EER
50°	70°db	267.36	173.08	0.65	15.63	320.69	17.1
60°		248.64	162.18	0.65	16.60	305.29	15.0
70°		229.91	151.74	0.66	17.57	289.89	13.1
85°		201.82	136.57	0.68	19.04	266.79	10.6
100°		173.73	121.54	0.70	20.50	243.69	8.5
50°	75°db	286.76	207.71	0.72	15.70	340.36	18.3
60°		266.71	194.73	0.73	16.69	323.66	16.0
70°		246.67	182.28	0.74	17.67	306.96	14.0
85°		216.60	164.22	0.76	19.14	281.91	11.3
100°		186.53	146.32	0.78	20.61	256.87	9.1
50°	80°db	315.13	229.73	0.73	15.82	369.11	19.9
60°		293.16	215.43	0.73	16.81	350.51	17.4
70°		271.18	201.71	0.74	17.79	331.91	15.2
85°		238.22	181.80	0.76	19.28	304.01	12.4
100°		205.26	162.08	0.79	20.76	276.11	9.9
50°	85°db	343.50	251.98	0.73	15.93	397.87	21.6
60°		319.60	236.34	0.74	16.93	377.37	18.9
70°		295.70	221.34	0.75	17.92	356.86	16.5
85°		259.84	199.56	0.77	19.42	326.11	13.4
100°		223.99	177.99	0.79	20.91	295.36	10.7

HEATING

EFT Range (Standard) 50°F to 80°F						EFT Range (Ext. Range Option) 25°F to 80°F	
Entering Fluid Temp. (°F)	Entering Air Temp. (°F)	Total Capacity (MBtuH)	Power Input (kW)	Heat of Abs. (MBtuH)	COP		
50°	60°	257.23	18.17	195.23	4.1		
60°		295.24	19.60	228.36	4.4		
70°		333.25	21.03	261.49	4.6		
80°		371.26	22.46	294.61	4.8		
50°		70°	243.46	18.47	180.42	3.9	
60°	279.38		19.93	211.36	4.1		
70°	315.29		21.39	242.29	4.3		
80°	351.20		22.85	273.23	4.5		
50°	80°		227.29	18.85	162.97	3.5	
60°		260.74	20.34	191.32	3.8		
70°		294.18	21.83	219.67	3.9		
80°		327.62	23.32	248.02	4.1		

LOW TEMP HEATING

Extended Range Option Required Antifreeze Required					
Temp	Temp	Capacity	Power	Heat	COP
25°	60°	159.03	14.59	109.23	3.2
30°		177.66	15.31	125.42	3.4
40°		214.92	16.74	157.80	3.8
25°	70°	150.67	14.83	100.07	3.0
30°		168.28	15.56	115.19	3.2
40°		203.48	17.01	145.42	3.5
25°	80°	140.86	15.12	89.27	2.7
30°		157.26	15.86	103.12	2.9
40°		190.05	17.35	130.82	3.2

Units are complete packages featuring 2 stage operation and containing compressors, reversing valve, expansion valve metering devices, and heat exchangers. Also included are safety controls: Overload protection for motors, high and low refrigerant pressure switches and a solid state lock-out circuit.

Extended range option includes insulated water coils.

Performance based on ARI/ISO rated air flow, fluid flow and voltage. For conditions other than rated, consult the FHP EAD selection software. Due to variations in installation actual performance may vary marginally from tabulated values.

As a result of continuing research and development, specifications are subject to change without notice.
EM240HZip6 mod2 Rev: 7-02

FHP MANUFACTURING COMPANY

601 N.W. 65th Court - Fort Lauderdale, FL 33309

Phone: (954) 776-5471 - Fax: (800) 776-5529

<http://www.fhp-mfg.com>



2 STAGE VERTICAL PACKAGED UNITS SPECIFICATION DATA SHEET

FHP MANUFACTURING HIGH-EFFICIENCY WATER SOURCE HEAT PUMPS

EM300

ENERGY-MISER

ELECTRICAL SPECIFICATIONS

Electrical Characteristics	Elect. Symbol	Compressor (x2)		Blower (x2)		Loop Pump		Min. Circuit Amps	Max. Fuse/Breaker
		RLA	LRA	FLA	HP	FLA	HP		
208/230-3-60	-3	43.0	285.0	9.0	3	-	-	114.8	150
460-3-60	-4	20.5	138.0	4.5	3	-	-	55.1	70
575-3-60	-5	14.3	100.0	3.6	3	-	-	39.4	50

MECHANICAL SPECIFICATIONS

Refrigerant: R-22			
Air Coil			
Square Feet	Rows Deep	Tube O.D.	Fins/Inch
18.1	3	3/8	14
Water Coil			
Type	Work Press		
Coaxial	450 psig		
Blower Size	Compr Type		
15 x 15 BD	Scroll		
Net Weight	Ship Weight		
1,315 lbs	1,405 lbs		

BLOWER PERFORMANCE

Available External Static Pressure (Inches of Water, Gauge. Wet Coil and Filter Included)												
Blower Speed	0.10	0.20	0.30	0.40	0.50	0.60	0.70	0.80	0.90	1.00	1.10	1.20
Closed	-	-	-	-	10000	9650	9300	8950	8600	8200	-	-
1/2 Open	-	10500	10100	9700	8900	8500	8100	-	-	-	-	-
Open	9900	9100	8700	8300	-	-	-	-	-	-	-	-



FLUID PRESSURE DROP

Fluid Flow (GPM)	Pressure Drop	
	(FOH)	(PSIG)
40	6.17	2.67
50	9.22	3.99
60	12.80	5.54
75	19.13	8.28
85	23.96	10.37

PERFORMANCE DATA Rated in accordance with ISO 13256-1 at 10,000 CFM and 75.0 GPM

Water Loop				Ground Water				Ground Loop (Ext. Range Required)			
Cooling		Heating		Cooling		Heating		Cooling		Heating	
Capacity	EER	Capacity	COP	Capacity	EER	Capacity	COP	Capacity	EER	Capacity	COP
285,000	12.4	360,000	4.1	350,000	18.1	290,000	3.7	300,000	13.4	210,000	2.9

CAPACITY DATA All performance at 10,000 CFM and 75.0 GPM

COOLING							
EFT Range (Standard) 50°F to 100°F				EFT Range (Ext. Range Option) 45°F to 110°F			
Entering Fluid Temp. (°F)	Entering Air Temp. (°F)	Total Capacity (MBtuH)	Sensible Capacity (MBtuH)	Sensible to Total Ratio	Power Input (kW)	Heat of Reject (MBtuH)	EER
50°	70°db	314.92	208.06	0.66	18.34	377.52	17.2
60°		294.27	195.99	0.67	19.71	361.53	14.9
70°		273.63	184.47	0.67	21.07	345.53	13.0
85°		242.67	167.83	0.69	23.11	321.54	10.5
100°		211.71	151.46	0.72	25.15	297.55	8.4
50°	75°db	337.43	248.74	0.74	18.45	400.38	18.3
60°		315.33	234.36	0.74	19.82	382.96	15.9
70°		293.23	220.64	0.75	21.18	365.54	13.8
85°		260.09	200.82	0.77	23.24	339.40	11.2
100°		226.95	181.31	0.80	25.29	313.27	9.0
50°	80°db	370.35	274.61	0.74	18.59	433.80	19.9
60°		346.13	258.76	0.75	19.97	414.29	17.3
70°		321.91	243.64	0.76	21.35	394.78	15.1
85°		285.57	221.80	0.78	23.42	365.51	12.2
100°		249.24	200.30	0.80	25.49	336.25	9.8
50°	85°db	403.28	300.74	0.75	18.73	467.21	21.5
60°		376.93	283.42	0.75	20.12	445.61	18.7
70°		350.58	266.87	0.76	21.52	424.02	16.3
85°		311.06	242.99	0.78	23.60	391.62	13.2
100°		271.54	219.48	0.81	25.69	359.22	10.6

HEATING					
EFT Range (Standard) 50°F to 80°F			EFT Range (Ext. Range Option) 25°F to 80°F		
Entering Fluid Temp. (°F)	Entering Air Temp. (°F)	Total Capacity (MBtuH)	Power Input (kW)	Heat of Abs. (MBtuH)	COP
50°	60°	305.82	23.69	224.99	3.8
60°		348.16	24.92	263.11	4.1
70°		390.50	26.15	301.24	4.4
80°		432.84	27.39	339.36	4.6
50°		70°	289.19	24.12	206.88
60°	329.19		25.37	242.59	3.8
70°	369.19		26.63	278.29	4.1
80°	409.19		27.89	314.00	4.3
50°	80°		269.64	24.64	185.53
60°		306.90	25.93	218.39	3.5
70°		344.15	27.22	251.25	3.7
80°		381.40	28.51	284.11	3.9

LOW TEMP HEATING					
Extended Range Option Required Antifreeze Required					
Entering Fluid Temp. (°F)	Entering Air Temp. (°F)	Total Capacity (MBtuH)	Power Input (kW)	Heat of Abs. (MBtuH)	COP
25°	60°	196.06	20.60	125.75	2.8
30°		216.81	21.22	144.40	3.0
40°		258.32	22.45	181.69	3.4
25°	70°	185.48	20.97	113.91	2.6
30°		205.09	21.60	131.37	2.8
40°		244.30	22.86	166.29	3.1
25°	80°	173.05	21.43	99.93	2.4
30°		191.31	22.07	115.99	2.5
40°		227.84	23.36	148.12	2.9

Units are complete packages containing two compressors with independent refrigeration circuits, reversing valves, expansion valve metering devices, and heat exchangers. Also included are safety controls: Overload protection for motors, high and low refrigerant pressure switches and a solid state lock-out circuit.

Extended range option includes insulated water coils.

Performance based on ARI/ISO rated air flow, fluid flow and voltage. For conditions other than rated, consult the FHP EAD selection software. Due to variations in installation actual performance may vary marginally from tabulated values.

As a result of continuing research and development, specifications are subject to change without notice.
EM300ip6 mod2 Rev: 7-02

FHP MANUFACTURING COMPANY
601 N.W. 65th Court - Fort Lauderdale, FL 33309
Phone: (954) 776-5471 - Fax: (800) 776-5529
<http://www.fhp-mfg.com>



2 STAGE VERTICAL PACKAGED UNITS SPECIFICATION DATA SHEET

FHP MANUFACTURING HIGH-EFFICIENCY WATER SOURCE HEAT PUMPS

EM360

ENERGY-MISER

ELECTRICAL SPECIFICATIONS

Electrical Characteristics	Elect. Symbol	Compressor (x2)		Blower (x2)		Loop Pump		Min. Circuit Amps	Max. Fuse/Breaker
		RLA	LRA	FLA	HP	FLA	HP		
208/230-3-60	-3	52.6	425.0	12.2	5	-	-	142.8	175
460-3-60	-4	23.7	187.0	6.1	5	-	-	65.5	80
575-3-60	-5	20.5	148.0	5.4	5	-	-	57.0	80

MECHANICAL SPECIFICATIONS

Refrigerant: R-22			
Air Coil			
Square Feet	Rows Deep	Tube O.D.	Fins/Inch
27.0	3	3/8	14
Water Coil			
Type	Work Press		
Coaxial	450 psig		
Blower Size	Compr Type		
15 x 15 BD	Scroll		
Net Weight	Ship Weight		
1,600 lbs	1,700 lbs		

BLOWER PERFORMANCE

Available External Static Pressure (Inches of Water, Gauge. Wet Coil and Filter Included)												
Blower Speed	0.20	0.30	0.40	0.60	0.80	1.00	1.20	1.40	1.60	1.80	2.00	2.20
Closed	-	-	-	-	-	-	-	-	-	-	12900	10800
1/2 Open	-	-	-	-	-	13050	11850	10350	7500	-	-	-
Open	12200	11575	10950	9600	7800	-	-	-	-	-	-	-



FLUID PRESSURE DROP

Fluid Flow (GPM)	Pressure Drop	
	(FOH)	(PSIG)
50	8.5	3.7
70	15.6	6.8
80	19.8	8.6
90	24.5	10.6
100	29.6	12.8

PERFORMANCE DATA Rated in accordance with ISO 13256-1 at 12,000 CFM and 90.0 GPM

Water Loop				Ground Water				Ground Loop (Ext. Range Required)			
Cooling		Heating		Cooling		Heating		Cooling		Heating	
Capacity	EER	Capacity	COP	Capacity	EER	Capacity	COP	Capacity	EER	Capacity	COP
372,000	14.4	420,000	4.2	455,000	21.5	333,000	3.8	389,000	16	240,000	3.2

CAPACITY DATA All performance at 12,000 CFM and 90.0 GPM

COOLING		EFT Range (Standard) 50°F to 100°F		EFT Range (Ext. Range Option) 45°F to 110°F		Sensible to Total Ratio	Power Input (kW)	Heat of Reject (MBtuH)	EER
Entering Fluid Temp. (°F)	Entering Air Temp. (°F)	Total Capacity (MBtuH)	Sensible Capacity (MBtuH)	Total Capacity (MBtuH)	Sensible Capacity (MBtuH)				
50°	70°db	397.02	257.84	0.65	23.62	477.63	16.8		
60°		370.82	242.58	0.65	25.33	457.26	14.6		
70°		344.62	228.05	0.66	27.04	436.90	12.7		
85°		305.32	207.12	0.68	29.60	406.35	10.3		
100°		266.02	186.59	0.70	32.16	375.80	8.3		
50°	75°db	426.34	310.82	0.73	23.73	507.31	18.0		
60°		398.29	292.64	0.73	25.44	485.14	15.7		
70°		370.25	275.33	0.74	27.16	462.96	13.6		
85°		328.18	250.41	0.76	29.74	429.70	11.0		
100°		286.12	225.95	0.79	32.32	396.44	8.9		
50°	80°db	469.23	344.52	0.73	23.88	550.72	19.7		
60°		438.48	324.49	0.74	25.61	525.89	17.1		
70°		407.74	305.41	0.75	27.34	501.07	14.9		
85°		361.62	277.94	0.77	29.95	463.83	12.1		
100°		315.51	250.98	0.80	32.55	426.59	9.7		
50°	85°db	512.11	378.56	0.74	24.03	594.12	21.3		
60°		478.67	356.65	0.75	25.78	566.64	18.6		
70°		445.23	335.79	0.75	27.52	539.17	16.2		
85°		395.06	305.75	0.77	30.15	497.95	13.1		
100°		344.90	276.27	0.80	32.77	456.74	10.5		

HEATING

HEATING		EFT Range (Standard) 50°F to 80°F		EFT Range (Ext. Range Option) 25°F to 80°F		Heat of Abs. (MBtuH)	COP
Entering Fluid Temp. (°F)	Entering Air Temp. (°F)	Total Capacity (MBtuH)	Power Input (kW)	Total Capacity (MBtuH)	Power Input (kW)		
50°	60°	366.97	30.73	262.10	3.5		
60°		417.85	32.73	306.14	3.7		
70°		468.73	34.74	350.17	4.0		
80°		519.61	36.74	394.21	4.1		
50°		70°	347.76	31.21	241.24	3.3	
60°	395.83		33.25	282.34	3.5		
70°	443.90		35.30	323.43	3.7		
80°	491.97		37.34	364.52	3.9		
50°	80°		325.19	31.80	216.64	3.0	
60°		369.96	33.90	254.27	3.2		
70°		414.73	35.99	291.90	3.4		
80°		459.49	38.08	329.53	3.5		

LOW TEMP HEATING

LOW TEMP HEATING		Extended Range Option Required Antifreeze Required			
Entering Fluid Temp. (°F)	Entering Air Temp. (°F)	Total Capacity (MBtuH)	Power Input (kW)	Heat of Abs. (MBtuH)	COP
25°	60°	235.07	25.71	147.31	2.7
30°		260.01	26.72	168.83	2.9
40°		309.89	28.72	211.86	3.2
25°	70°	223.13	26.10	134.04	2.5
30°		246.69	27.12	154.12	2.7
40°		293.82	29.17	194.27	3.0
25°	80°	209.10	26.58	118.39	2.3
30°		231.04	27.62	136.76	2.5
40°		274.93	29.71	173.52	2.7

Units are complete packages containing two compressors with independent refrigeration circuits, reversing valves, expansion valve metering devices, and heat exchangers. Also included are safety controls: Overload protection for motors, high and low refrigerant pressure switches and a solid state lock-out circuit.

Extended range option includes insulated water coils.

Performance based on ARI/ISO rated air flow, fluid flow and voltage. For conditions other than rated, consult the FHP EAD selection software. Due to variations in installation actual performance may vary marginally from tabulated values.

As a result of continuing research and development, specifications are subject to change without notice.
EM360ip6 mod2 Rev: 8-06

FHP MANUFACTURING COMPANY

601 N.W. 65th Court - Fort Lauderdale, FL 33309

Phone: (954) 776-5471 - Fax: (800) 776-5529

<http://www.fhp-mfg.com>