



GUIDE SPECIFICATIONS

ES Series Two Stage R-410A

GENERAL

Units shall be performance certified to ISO standard 13256-1 for Water Loop Heat Pump, Ground Water Heat Pump and Ground Loop Heat Pump applications. Units shall be Underwriter Laboratories (UL and ULc) listed for safety on all models. Each unit shall be run tested at the factory. Each unit shall be pallet mounted and stretch wrapped. The units shall be manufactured in an ISO9001:2000 certified facility.

The units shall be warranted by the manufacturer against defects in materials and workmanship for a period of i) in the case of residentially sold units having the last digit of the serial number as a 'T'; five years on all parts and 10 years on the refrigerant circuit components ii) on all other units; five years on the compressor and one year on all other parts.

The units shall be designed to operate with entering fluid temperatures between 50°F (10°C) and 110°F (43.3°C) in cooling and temperatures between 25°F (-3.9°C) and 80°F (27°C) in heating as manufactured by FHP Manufacturing in Fort Lauderdale, Florida.

CASING & CABINET

The cabinet shall be fabricated from heavy-gauge steel finished with Galvalume® plus, an aluminum-zinc alloy with a clear acrylic coating for additional corrosion protection. The interior shall be insulated with ½" (12.7mm) thick, multi density, coated, glass fiber. All units shall allow sufficient service access to replace the compressor without unit removal. One blower and two compressor compartment access panels shall be removable with supply and return ductwork in place. A duct collar shall be provided on the supply air opening. A filter rack with 1" (25.4mm) thick disposable filters and a 1" (25.4mm) return air duct collar shall be provided with each unit. The units shall have an insulated divider panel between the air handling section and the compressor section to minimize the transmission of compressor noise, and to permit service testing without air bypass. Units shall have a stainless steel condensate drain pan.

REFRIGERATION CIRCUITS

All units shall contain a sealed refrigerant circuit including a hermetic two stage scroll compressor, bi-directional thermal expansion valve metering device, finned tube air-to-refrigerant heat exchanger, refrigerant reversing valve and service ports. Compressor shall be high efficiency scroll type, designed for heat pump duty, quiet operation and mounted on rubber vibration isolators. Compressor motors shall be equipped with overload protection. Refrigerant reversing valves shall be pilot operated sliding piston type with replaceable encapsulated magnetic coils energized only during the cooling cycle. The finned tube coil shall be constructed of lanced aluminum fins not exceeding fourteen fins per inch bonded to rifled copper tubes in a staggered pattern not less than three rows deep and have a 450 PSIG (3100 kPa) working pressure. Coils shall have a baked polyester enamel coating for protection against most airborne chemicals. Coil end plates shall be aluminum. The coaxial water-to-refrigerant heat exchanger shall be constructed of a convoluted copper (optional cupronickel) inner tube and steel outer tube with a designed refrigerant working pressure of 450 PSIG (3100 kPa) and a designed water side working pressure of no less than 400 PSIG (2750 kPa). The water-to-refrigerant heat exchanger shall be insulated to prevent condensation at low fluid temperatures.

FAN MOTOR & ASSEMBLY

The fan shall be direct drive centrifugal forward curved type with a dynamically balanced wheel. The housing and wheel shall be designed for quiet low velocity operation. The fan housing shall be removable from the unit without disconnecting the supply air ductwork for servicing of the fan motor. The fan motor shall be an ECM-2 microprocessor controlled DC type motor with internal programming factory set for the spe-

cific unit and featuring soft start/stop and a delay off feature for maximum efficiency and quiet operation. Air flow rates shall be varied according to the staging of the unit. There will further be provisions for adjusting the air delivery of the motor and blower by +/- 15% from rated air flow.

ELECTRICAL

Controls and safety devices will be factory wired and mounted within the unit. Controls shall include compressor contactor, 24V transformer, reversing valve coil and solid state lock-out controller (UPM). The UPM controller shall include the following features: diagnostic LED's, low pressure bypass time delay (to prevent nuisance low pressure lock-outs during operation with low fluid temperatures), anti short cycle time delay, random start time delay and one time intelligent reset. When the safety controls are activated the lock-out circuit shall reset itself the first time. If the safety controls are subsequently activated, then the lock-out circuit shall disable the compressor until it is reset at the thermostat or main circuit breaker to prevent compressor operation during fault conditions. A lock-out indicating terminal shall be provided in the low voltage circuit. Safety devices include a low pressure cutout set a 40 PSIG (280 kPa) for loss of charge protection (freezestat and/or high discharge gas temperature sensor is not acceptable) and a high pressure cutout control set at 600 PSIG (4100 kPa).

The ECM motor interface board shall provide a screw type terminal block for thermostat connection, LED's to indicate thermostat status and air delivery. It shall also provide a means of changing the motor program to any of up to four pre-programmed options. Direct wiring of the motor control harness to the thermostat is not acceptable.

A terminal block with screw terminals shall be provided for control wiring. An optional condensate overflow device shall be factory installed to stop compressor operation if drain pan overflow is imminent. An optional energy management relay to allow unit control by an external source shall be factory installed.

PIPING

Supply, return water and condensate drain connections shall be brass female pipe thread fittings and mounted flush to cabinet exterior.

INTERNAL ELECTRIC HEAT

208/230-1-60 volt units shall be equipped with optional factory installed internal electric resistance heat for auxiliary and emergency heat. Electric heater must be Underwriter's Laboratories (UL and ULc) approved for safety when installed in the unit. External heater packages or heater packages not specifically listed for use with the unit are unacceptable. Electric heater packages shall include a heater collar mounted to the blower outlet, individual thermal overload protected heater elements no greater than 5kW each and magnetic contactors. Heater packages shall have a separate power supply connection from the compressor and this power supply shall also power the unit blower motor and control transformer for safe operation.

HEAT RECOVERY PACKAGE

208/230 volt units shall be equipped with a optional factory installed internal heat recovery kit for domestic hot water production. This kit shall include an internally protected pump, double walled coaxial water-to-refrigerant heat exchanger, 140°F (60°C) hot water temperature limit switch and an on/off switch/circuit breaker.

LOOP PUMP PACKAGE - CONSULT FACTORY

208/230-1-60 volt units shall be equipped with an optional factory installed ground loop pump kit. This kit shall include a 1/6 HP loop pump, isolation valves and a set of purge connections for purging and pressurizing the ground loop with the unit in place. The pump, all piping and valves shall be internal to the unit.



FHP Manufacturing Co.
 601 N.W. 65th Court
 Fort Lauderdale, FL 33309
 Phone: (954) 776-5471
 Fax: (800) 776-5529
<http://www.fhp-mfg.com>

ES Two Stage Series Vertical Dimensions

MODEL	A	B	C	D	E	F	G	H	J	K	M	N	P	Q	Condenser Water Connections	Recommended Replacement Nominal Filter Size
	Width	Depth	Height								R/A Duct Flg Width	R/A Duct Flg Height	Filter Rack Height			
ES025, 035	21.50	26.00	47.25	13.75	15.75	6.13	5.25	5.25	8.00	15.25	22.00	22.25	24.00	4.00	3/4" F.P.T.	24 X 24 X 1
ES049	24.00	32.75	47.25	15.75	15.75	8.38	5.50	5.25	8.00	16.25	28.50	22.25	24.00	4.00	1" F.P.T.	24 X 30 X 1
ES061	26.00	33.25	51.25	17.75	17.75	7.13	6.25	5.25	8.00	18.50	28.50	22.25	24.00	4.00	1" F.P.T.	24 X 30 X 1
ES071	26.00	33.25	58.25	17.75	17.75	8.00	7.75	5.25	8.00	18.50	28.50	30.25	32.00	1.50	1" F.P.T.	16 X 30 X 1 (2)

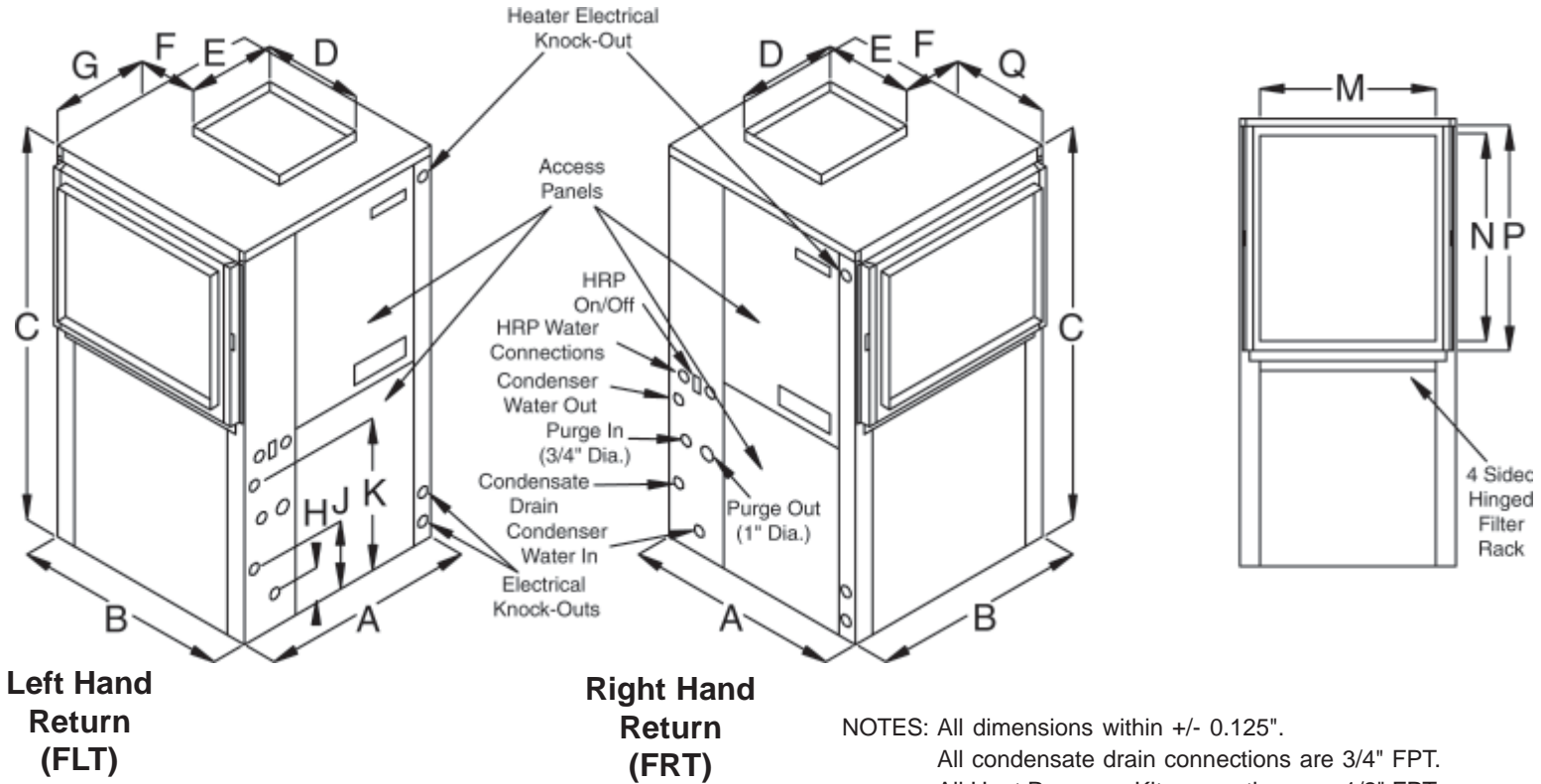

NOTES: All dimensions within +/- 0.125".
 All condensate drain connections are 3/4" FPT.
 All Heat Recovery Kit connections are 1/2" FPT.
 Internal electric heat available on 208-230/1/60 top discharge units only
 Internal Loop Pump available on 208-230 volt units only.
 Internal Heat Recovery Kit available on 208-230 volt units only.
 Specifications subject to change without notice.



FHP Manufacturing Co.
 601 N.W. 65th Court
 Fort Lauderdale, FL 33309
 Phone: (954) 776-5471
 Fax: (800) 776-5529
 http://www.fhp-mfg.com

ES Two Stage Series Horizontal Dimensions

MODEL	A	B	C	D	E	F	G	H	J	K	M	N	P	Q	R	T	Condenser Water Connections	Recommended Replacement Nom. Filter Size
	Width	Depth	Height		R/A Duct Flg Width									Filter Rack Height	R/A Duct Flg Height			
ES025, 035	26.00	54.50	21.75	2.00	30.00	22.50	5.25	15.25	4.50	13.75	3.00	15.75	4.50	3.00	20.50	18.50	3/4" F.P.T.	18 X 20 X 1 (2)
ES049	30.00	68.00	21.75	2.50	33.50	32.00	5.25	16.25	5.81	15.75	3.00	15.75	5.81	3.00	20.50	18.50	1" F.P.T.	18 X 20 X 1 (2)
ES061	30.00	68.00	21.75	2.50	33.50	32.00	5.25	18.50	7.66	17.75	2.00	17.75	7.66	2.00	20.50	18.50	1" F.P.T.	18 X 20 X 1 (2)
ES071	30.00	78.00	21.75	2.50	44.00	31.50	5.25	18.50	3.50	16.75	3.75	16.75	7.66	1.00	20.25	18.50	1" F.P.T.	20x24x1 (2)

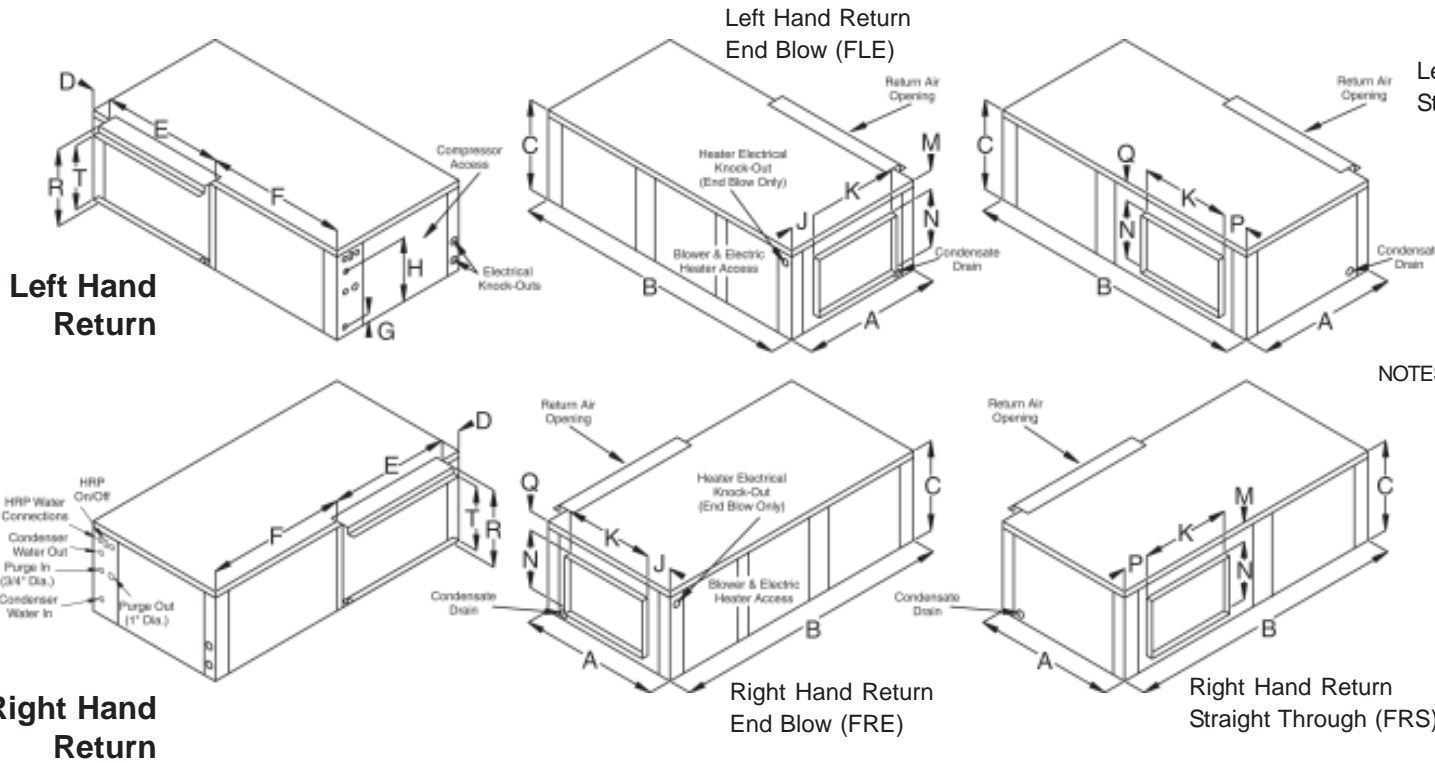

Left Hand Return Straight Through (FLS)

NOTES: All dimensions within +/- 0.125".
 All condensate drain connections are 3/4" FPT.
 All Heat Recovery connections are 1/2" FPT.
 Internal electric heat available on 208-230 volt units only
 Internal Loop Pump available on 208-230 volt units only.
 Internal Heat Recovery Kit available on 208-230 volt units only.
 Units can be field converted between end blow and straight through supply air configurations.
 Specifications subject to change without notice.



FHP Manufacturing Co.
 601 N.W. 65th Court
 Fort Lauderdale, FL 33309
 Phone: (954) 776-5471
 Fax: (800) 776-5529
<http://www.fhp-mfg.com>

ES Two Stage Series Counterflow Dimensions

MODEL	A	B	C	D	E	F	G	H	J	K	M	N	P	Condenser Water Connections	Recommended Replacement Nominal Filter Size
	Width	Depth	Height	Blower Opening	Blower Opening						R/A Duct Flg Width	R/A Duct Flg Height	Filter Rack Height		
ES025, 035	21.50	26.00	47.25	9.25	10.25	8.38	5.00	7.00	17.00	9.75	22.00	22.00	24.00	3/4" F.P.T.	24 X 24 X 1
ES049	24.00	32.75	47.25	10.75	11.50	11.13	6.88	7.50	18.50	8.75	28.00	22.00	24.00	1" F.P.T.	24 X 30 X 1
ES061	26.00	33.25	51.25	12.00	12.50	10.63	5.00	7.00	20.25	10.50	28.00	22.00	24.00	1" F.P.T.	24 X 30 X 1
ES071	26.00	33.25	58.25	12.75	13.50	9.75	4.50	7.00	20.25	11.00	28.00	30.00	32.00	1" F.P.T.	16 X 30 X 1 (2)

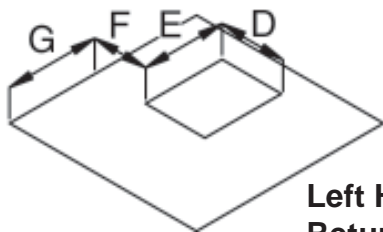
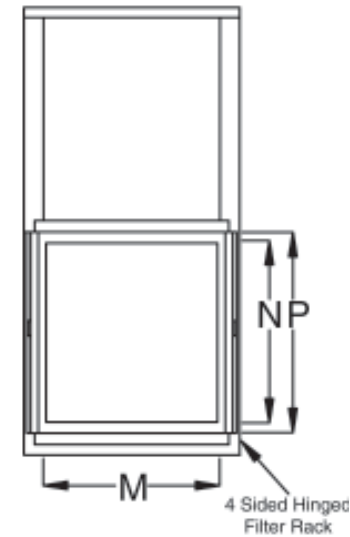
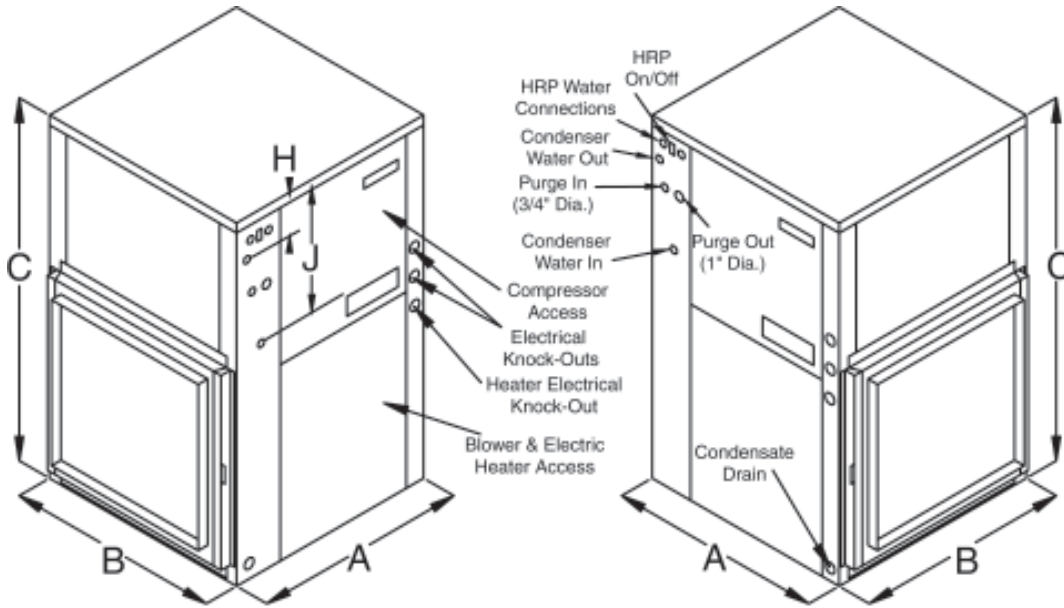

Left Hand Return (FLB)

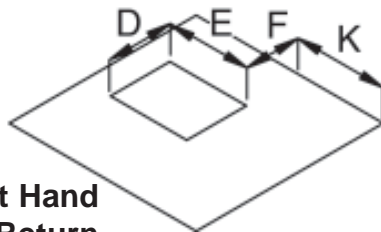

Right Hand Return (FRB)

NOTES: All dimensions within +/- 0.125".

All condensate drain connections are 3/4" FPT.

All Heat Recovery Kit connections are 1/2" FPT.

Internal electric heat available on 208-230/1/60 bottom discharge units only

Internal Loop Pump available on 208-230 volt units only.

Internal Heat Recovery Kit available on 208-230 volt units only.

Specifications subject to change without notice.



PACKAGED UNITS SPECIFICATION DATA SHEET

FHP MANUFACTURING HIGH-EFFICIENCY WATER SOURCE HEAT PUMPS

ES025

ENVIROSAVER

ELECTRICAL SPECIFICATIONS

Electrical Characteristics	Elect. Symbol	Compressor		Blower		Loop Pump		Min. Circuit Amps	Max. Fuse/Breaker
		RLA	LRA	FLA	HP	FLA	HP		
208/230-1-60	-1	11.4	52.0	2.8	1/3	-	-	18.8	30

MECHANICAL SPECIFICATIONS

Refrigerant: R-410A			
Air Coil			
Square Feet	Rows Deep	Tube O.D.	Fins/Inch
3.5	3	3/8	14
Water Coil			
Type	Work Press		
Coaxial	450 psig		
Blower Size	Compr Type		
9 x 7 DD	Scroll		
Net Weight	Ship Weight		
290 lbs	315 lbs		

BLOWER PERFORMANCE

Available External Static Pressure (Inches of Water, Gauge. Wet Coil and Filter Included)												
Blower Speed	0.10	0.20	0.30	0.40	0.50	0.60	0.70	0.80	0.90	1.00	1.10	1.20
+				575								
Norm				500								
-				425								



ISO 13256-1 CERTIFIED PERFORMANCE DATA Rated at 500 CFM and 6.0 GPM

Water Loop				Ground Water				Ground Loop			
Cooling		Heating		Cooling		Heating		Cooling		Heating	
Capacity	EER	Capacity	COP	Capacity	EER	Capacity	COP	Capacity	EER	Capacity	COP
18,800	17.5	20,500	5.1	21,000	30.0	18,000	4.6	20,000	24.5	15,500	4.0

FLUID PRESSURE DROP

Fluid Flow (GPM)	Pressure Drop	
	(FOH)	(PSIG)
5.0	3.1	1.3
7.0	5.7	2.5
9.0	8.9	3.8
11.0	12.8	5.6
12.0	15.0	6.5

CAPACITY DATA - PART LOAD

COOLING All performance at 500 CFM and 6.0 GPM							
Entering Fluid Temp. (°F)	Entering Air Temp. (°F)	Total Capacity (MBtuH)	Sensible Capacity (MBtuH)	Sensible to Total Ratio	Power Input (kW)	Heat of Reject (MBtuH)	EER
50°	70°db	18.47	11.91	0.64	0.61	20.56	30.1
60°		17.80	11.57	0.65	0.74	20.32	24.1
70°		17.13	11.28	0.66	0.86	20.08	19.8
85°		16.13	10.90	0.68	1.05	19.72	15.3
100°		15.13	10.58	0.70	1.24	19.36	12.2
50°	75°db	19.79	14.23	0.72	0.62	21.89	32.0
60°		19.07	13.83	0.73	0.74	21.61	25.7
70°		18.36	13.48	0.73	0.87	21.32	21.1
85°		17.28	13.03	0.75	1.06	20.89	16.3
100°		16.21	12.65	0.78	1.25	20.46	13.0
50°	80°db	21.72	15.71	0.72	0.62	23.84	34.9
60°		20.93	15.27	0.73	0.75	23.49	28.0
70°		20.15	14.88	0.74	0.88	23.14	23.0
85°		18.97	14.39	0.76	1.07	22.61	17.8
100°		17.80	13.97	0.78	1.26	22.08	14.2
50°	85°db	23.65	17.21	0.73	0.63	25.78	37.7
60°		22.79	16.73	0.73	0.75	25.37	30.2
70°		21.94	16.30	0.74	0.88	24.95	24.9
85°		20.66	15.76	0.76	1.07	24.33	19.2
100°		19.38	15.30	0.79	1.27	23.70	15.3

HEATING

Entering Fluid Temp. (°F)	Entering Air Temp. (°F)	Total Capacity (MBtuH)	Power Input (kW)	Heat of Abs. (MBtuH)	COP
50°	60°	19.07	1.19	15.02	4.7
60°		20.53	1.21	16.41	5.0
70°		21.98	1.22	17.80	5.3
80°		23.43	1.24	19.20	5.5
50°		70°	18.04	1.21	13.91
60°	19.41		1.23	15.22	4.6
70°	20.78		1.25	16.53	4.9
80°	22.15		1.26	17.84	5.1
50°	80°		16.81	1.24	12.60
60°		18.09	1.25	13.81	4.2
70°		19.37	1.27	15.03	4.5
80°		20.65	1.29	16.24	4.7

LOW TEMP HEATING

Antifreeze Required

25°	60°	15.14	1.14	11.24	3.9
30°		15.85	1.15	11.92	4.0
40°		17.28	1.17	13.28	4.3
25°	70°	14.32	1.16	10.34	3.6
30°		14.99	1.17	10.99	3.7
40°		16.34	1.19	12.27	4.0
25°	80°	13.35	1.19	9.29	3.3
30°		13.98	1.20	9.89	3.4
40°		15.23	1.22	11.08	3.7

Units are complete packages containing compressor, reversing valve, expansion valve metering device, ECM fan motor and heat exchangers. Also included are safety controls: Overload protection for motors, high and low refrigerant pressure switches and solid state lock-out circuit. Optional UL approved internal electric heater, factory installed with primary thermal overload protection and magnetic contactors (208/230-1-60 only) optional UL approved internal Heat Recovery Package and/or Ground Loop Pump with purge connections available

Performance based on ARI/ISO rated air flow, fluid flow and voltage. For conditions other than rated, consult the FHP EAD selection software. Due to variations in installation actual performance may vary marginally from tabulated values.

As a result of continuing research and development, specifications are subject to change without notice.
ES025.1IP60 Rev: 9-05

FHP MANUFACTURING COMPANY

601 N.W. 65th Court - Fort Lauderdale, FL 33309

Phone: (954) 776-5471 - Fax: (800) 776-5529

<http://www.fhp-mfg.com>



PACKAGED UNITS SPECIFICATION DATA SHEET

FHP MANUFACTURING HIGH-EFFICIENCY WATER SOURCE HEAT PUMPS

ES025

ENVIROSAVER

ELECTRICAL SPECIFICATIONS

Electrical Characteristics	Elect. Symbol	Compressor		Blower		Loop Pump		Min. Circuit Amps	Max. Fuse/Breaker
		RLA	LRA	FLA	HP	FLA	HP		
208/230-1-60	-1	11.4	52.0	2.8	1/3	-	-	18.8	30

MECHANICAL SPECIFICATIONS

Refrigerant: R-410A			
Air Coil			
Square Feet	Rows Deep	Tube O.D.	Fins/Inch
3.5	3	3/8	14
Water Coil			
Type	Work Press		
Coaxial	450 psig		
Blower Size	Compr Type		
9 x 7 DD	Scroll		
Net Weight	Ship Weight		
290 lbs	315 lbs		

BLOWER PERFORMANCE

Available External Static Pressure (Inches of Water, Gauge. Wet Coil and Filter Included)												
Blower Speed	0.10	0.20	0.30	0.40	0.50	0.60	0.70	0.80	0.90	1.00	1.10	1.20
+						920						
Norm						800						
-						680						



FLUID PRESSURE DROP

Fluid Flow (GPM)	Pressure Drop	
	(FOH)	(PSIG)
5.0	3.1	1.3
7.0	5.7	2.5
9.0	8.9	3.8
11.0	12.8	5.6
12.0	15.0	6.5

ISO 13256-1 CERTIFIED PERFORMANCE DATA Rated at 800 CFM and 6.0 GPM

Water Loop				Ground Water				Ground Loop			
Cooling		Heating		Cooling		Heating		Cooling		Heating	
Capacity	EER	Capacity	COP	Capacity	EER	Capacity	COP	Capacity	EER	Capacity	COP
26,000	16.0	30,000	5.0	29,000	24.0	25,000	4.6	27,500	18.7	19,000	3.8

CAPACITY DATA - FULL LOAD

COOLING All performance at 800 CFM and 6.0 GPM							
Entering Fluid Temp. (°F)	Entering Air Temp. (°F)	Total Capacity (MBtuH)	Sensible Capacity (MBtuH)	Sensible to Total Ratio	Power Input (kW)	Heat of Reject (MBtuH)	EER
50°	70°db	25.58	16.95	0.66	1.10	29.35	23.2
60°		24.66	16.47	0.67	1.25	28.94	19.7
70°		23.74	16.06	0.68	1.40	28.52	17.0
85°		22.36	15.52	0.69	1.62	27.90	13.8
100°		20.98	15.07	0.72	1.85	27.28	11.4
50°	75°db	27.40	20.24	0.74	1.11	31.19	24.7
60°		26.42	19.67	0.74	1.26	30.71	21.0
70°		25.43	19.18	0.75	1.41	30.24	18.1
85°		23.96	18.54	0.77	1.63	29.53	14.7
100°		22.48	18.00	0.80	1.86	28.82	12.1
50°	80°db	30.06	22.33	0.74	1.12	33.88	26.9
60°		28.98	21.71	0.75	1.27	33.31	22.8
70°		27.91	21.16	0.76	1.42	32.75	19.7
85°		26.29	20.46	0.78	1.65	31.90	16.0
100°		24.67	19.86	0.81	1.87	31.05	13.2
50°	85°db	32.73	24.44	0.75	1.13	36.57	29.1
60°		31.55	23.76	0.75	1.28	35.91	24.7
70°		30.38	23.16	0.76	1.43	35.26	21.2
85°		28.61	22.39	0.78	1.66	34.28	17.3
100°		26.85	21.75	0.81	1.89	33.29	14.2

HEATING

Entering Fluid Temp. (°F)	Entering Air Temp. (°F)	Total Capacity (MBtuH)	Power Input (kW)	Heat of Abs. (MBtuH)	COP
50°	60°	26.03	1.63	20.48	4.7
60°		29.23	1.71	23.38	5.0
70°		32.42	1.80	26.27	5.3
80°		35.62	1.89	29.17	5.5
50°		70°	24.61	1.66	18.96
60°	27.63		1.75	21.67	4.6
70°	30.64		1.84	24.38	4.9
80°	33.66		1.92	27.09	5.1
50°	80°		22.94	1.69	17.16
60°		25.75	1.78	19.66	4.2
70°		28.56	1.88	22.15	4.5
80°		31.37	1.97	24.65	4.7

LOW TEMP HEATING

Antifreeze Required

25°	60°	17.69	1.41	12.90	3.7
30°		19.26	1.45	14.31	3.9
40°		22.39	1.54	17.14	4.3
25°	70°	16.73	1.43	11.84	3.4
30°		18.21	1.48	13.17	3.6
40°		21.17	1.57	15.82	4.0
25°	80°	15.60	1.46	10.60	3.1
30°		16.97	1.51	11.82	3.3
40°		19.73	1.60	14.27	3.6

Units are complete packages containing compressor, reversing valve, expansion valve metering device, ECM fan motor and heat exchangers. Also included are safety controls: Overload protection for motors, high and low refrigerant pressure switches and solid state lock-out circuit. Optional UL approved internal electric heater, factory installed with primary thermal overload protection and magnetic contactors (208/230-1-60 only) optional UL approved internal Heat Recovery Package and/or Ground Loop Pump with purge connections available

Performance based on ARI/ISO rated air flow, fluid flow and voltage. For conditions other than rated, consult the FHP EAD selection software. Due to variations in installation actual performance may vary marginally from tabulated values.

As a result of continuing research and development, specifications are subject to change without notice.
ES025.2IP60 Rev: 9-05

FHP MANUFACTURING COMPANY

601 N.W. 65th Court - Fort Lauderdale, FL 33309

Phone: (954) 776-5471 - Fax: (800) 776-5529

<http://www.fhp-mfg.com>



PACKAGED UNITS SPECIFICATION DATA SHEET

FHP MANUFACTURING HIGH-EFFICIENCY WATER SOURCE HEAT PUMPS

ES035

ENVIROSAVER

ELECTRICAL SPECIFICATIONS

Electrical Characteristics	Elect. Symbol	Compressor		Blower		Loop Pump		Min. Circuit Amps	Max. Fuse/Breaker
		RLA	LRA	FLA	HP	FLA	HP		
208/230-1-60	-1	16.7	82.0	4.3	1/2	-	-	27.0	40
208/230-3-60	-3	12.4	58.0	4.3	1/2	-	-	21.6	30
460-3-60	-4	5.0	29.0	4.1	1/2	-	-	10.4	15

Note: 460 Volt Units (-4) Require Both Ground and Neutral Wires

MECHANICAL SPECIFICATIONS

Refrigerant: R-410A			
Air Coil			
Square Feet	Rows Deep	Tube O.D.	Fins/Inch
3.5	3	3/8	14
Water Coil			
Type	Work Press		
Coaxial	450 psig		
Blower Size	Compr Type		
9 x 7 DD	Scroll		
Net Weight	Ship Weight		
290 lbs	315 lbs		

BLOWER PERFORMANCE

Available External Static Pressure (Inches of Water, Gauge. Wet Coil and Filter Included)												
Blower Speed	0.10	0.20	0.30	0.40	0.50	0.60	0.70	0.80	0.90	1.00	1.10	1.20
+					900							
Norm					800							
-					700							



FLUID PRESSURE DROP

Fluid Flow (GPM)	Pressure Drop	
	(FOH)	(PSIG)
5	3.1	1.32
7	5.6	2.42
9	8.8	3.81
11	12.6	5.74
13	17.1	7.38

ISO 13256-1 CERTIFIED PERFORMANCE DATA Rated at 800 CFM and 9.0 GPM

Water Loop				Ground Water				Ground Loop			
Cooling		Heating		Cooling		Heating		Cooling		Heating	
Capacity	EER	Capacity	COP	Capacity	EER	Capacity	COP	Capacity	EER	Capacity	COP
24,000	17.0	27,000	5.3	27,000	28.0	22,500	4.5	27,000	24.5	20,500	4.0

CAPACITY DATA - PART LOAD

COOLING All performance at 800 CFM and 9.0 GPM							
Entering Fluid Temp. (°F)	Entering Air Temp. (°F)	Total Capacity (MBtuH)	Sensible Capacity (MBtuH)	Sensible to Total Ratio	Power Input (kW)	Heat of Reject (MBtuH)	EER
50°		23.89	15.37	0.64	0.88	26.90	27.0
60°	70°db	23.07	14.97	0.65	1.03	26.59	22.3
70°	61°wb	22.25	14.62	0.66	1.18	26.28	18.8
85°		21.02	14.18	0.67	1.41	25.82	15.0
100°		19.80	13.82	0.70	1.63	25.35	12.2
50°		25.60	18.39	0.72	0.89	28.63	28.8
60°	75°db	24.72	17.91	0.72	1.04	28.26	23.8
70°	63°wb	23.85	17.49	0.73	1.19	27.90	20.1
85°		22.53	16.97	0.75	1.41	27.35	15.9
100°		21.22	16.54	0.78	1.64	26.81	13.0
50°		28.10	20.31	0.72	0.89	31.15	31.4
60°	80°db	27.14	19.78	0.73	1.05	30.71	26.0
70°	67°wb	26.18	19.32	0.74	1.20	30.26	21.9
85°		24.74	18.74	0.76	1.42	29.60	17.4
100°		23.30	18.27	0.78	1.65	28.93	14.1
50°		30.60	22.25	0.73	0.90	33.68	34.0
60°	85°db	29.56	21.67	0.73	1.05	33.15	28.1
70°	71°wb	28.52	21.17	0.74	1.21	32.63	23.7
85°		26.95	20.53	0.76	1.43	31.84	18.8
100°		25.38	20.02	0.79	1.66	31.06	15.3

Units are complete packages containing compressor, reversing valve, expansion valve metering device, ECM fan motor and heat exchangers. Also included are safety controls: Overload protection for motors, high and low refrigerant pressure switches and solid state lock-out circuit. Optional UL approved internal electric heater, factory installed with primary thermal overload protection and magnetic contactors (208/230-1-60 only) optional UL approved internal Heat Recovery Package and/or Ground Loop Pump with purge connections available

Performance based on ARI/ISO rated air flow, fluid flow and voltage. For conditions other than rated, consult the FHP EAD selection software. Due to variations in installation actual performance may vary marginally from tabulated values.

As a result of continuing research and development, specifications are subject to change without notice.
ES035.1IP60 Rev: 10-06

HEATING EFT Range (Standard) 25°F to 80°F

Entering Fluid Temp. (°F)	Entering Air Temp. (°F)	Total Capacity (MBtuH)	Power Input (kW)	Heat of Abs. (MBtuH)	COP
50°		24.80	1.56	19.48	4.7
60°	60°	26.69	1.57	21.35	5.0
70°		28.58	1.57	23.22	5.3
80°		30.47	1.58	25.09	5.7
50°		23.46	1.59	18.04	4.3
60°	70°	25.24	1.59	19.80	4.6
70°		27.02	1.60	21.57	5.0
80°		28.81	1.60	23.33	5.3
50°		21.87	1.62	16.34	4.0
60°	80°	23.53	1.63	17.98	4.2
70°		25.20	1.63	19.62	4.5
80°		26.86	1.64	21.26	4.8

LOW TEMP HEATING Antifreeze Required

25°		19.69	1.55	14.42	3.7
30°	60°	20.62	1.55	15.33	3.9
40°		22.47	1.55	17.16	4.2
25°		18.63	1.57	13.26	3.5
30°	70°	19.50	1.58	14.12	3.6
40°		21.25	1.58	15.85	3.9
25°		17.37	1.61	11.89	3.2
30°	80°	18.19	1.61	12.69	3.3
40°		19.82	1.62	14.30	3.6

FHP MANUFACTURING COMPANY

601 N.W. 65th Court - Fort Lauderdale, FL 33309

Phone: (954) 776-5471 - Fax: (800) 776-5529

<http://www.fhp-mfg.com>



PACKAGED UNITS SPECIFICATION DATA SHEET

FHP MANUFACTURING HIGH-EFFICIENCY WATER SOURCE HEAT PUMPS

ES035

ENVIROSAVER

ELECTRICAL SPECIFICATIONS

Electrical Characteristics	Elect. Symbol	Compressor		Blower		Loop Pump		Min. Circuit Amps	Max. Fuse/Breaker
		RLA	LRA	FLA	HP	FLA	HP		
208/230-1-60	-1	16.7	82.0	4.3	1/2	-	-	27.0	40
208/230-3-60	-3	12.4	58.0	4.3	1/2	-	-	21.6	30
460-3-60	-4	5.0	29.0	4.1	1/2	-	-	10.4	15

Note: 460 Volt Units (-4) Require Both Ground and Neutral Wires

MECHANICAL SPECIFICATIONS

Refrigerant: R-410A			
Air Coil			
Square Feet	Rows Deep	Tube O.D.	Fins/Inch
3.5	3	3/8	14
Water Coil			
Type	Work Press		
Coaxial	450 psig		
Blower Size	Compr Type		
9 x 7 DD	Scroll		
Net Weight	Ship Weight		
290 lbs	315 lbs		

BLOWER PERFORMANCE

Available External Static Pressure (Inches of Water, Gauge. Wet Coil and Filter Included)												
Blower Speed	0.10	0.20	0.30	0.40	0.50	0.60	0.70	0.80	0.90	1.00	1.10	1.20
+						1380						
Norm						1200						
-						1020						



ISO 13256-1 CERTIFIED PERFORMANCE DATA Rated at 1200 CFM and 9.0 GPM

Water Loop				Ground Water				Ground Loop			
Cooling		Heating		Cooling		Heating		Cooling		Heating	
Capacity	EER	Capacity	COP	Capacity	EER	Capacity	COP	Capacity	EER	Capacity	COP
36,000	14.6	43,000	4.8	42,000	21.6	36,000	4.2	38,000	17.2	28,000	3.8

FLUID PRESSURE DROP

Fluid Flow (GPM)	Pressure Drop	
	(FOH)	(PSIG)
5.0	3.1	1.32
7.0	5.6	2.42
9.0	8.8	3.81
11.0	12.6	5.47
13.0	17.1	7.38

CAPACITY DATA - FULL LOAD

COOLING All performance at 1200 CFM and 9.0 GPM EFT Range (Standard) 50°F to 100°F

Entering Fluid Temp. (°F)	Entering Air Temp. (°F)	Total Capacity (MBtuH)	Sensible Capacity (MBtuH)	Sensible to Total Ratio	Power Input (kW)	Heat of Reject (MBtuH)	EER
50°	70°db	37.18	24.24	0.65	1.86	43.53	20.0
60°		35.27	23.18	0.66	2.04	42.23	17.3
70°		33.36	22.20	0.67	2.22	40.94	15.0
85°		30.50	20.82	0.68	2.49	39.00	12.2
100°		27.63	19.52	0.71	2.76	37.06	10.0
50°	75°db	39.84	28.99	0.73	1.87	46.22	21.3
60°		37.80	27.73	0.73	2.05	44.80	18.4
70°		35.75	26.56	0.74	2.23	43.38	16.0
85°		32.69	24.92	0.76	2.51	41.24	13.0
100°		29.62	23.37	0.79	2.78	39.11	10.7
50°	80°db	43.73	32.01	0.73	1.88	50.17	23.2
60°		41.49	30.63	0.74	2.07	48.55	20.1
70°		39.25	29.33	0.75	2.25	46.94	17.4
85°		35.89	27.53	0.77	2.53	44.51	14.2
100°		32.53	25.82	0.79	2.80	42.09	11.6
50°	85°db	47.63	35.07	0.74	1.90	54.11	25.1
60°		45.19	33.55	0.74	2.08	52.30	21.7
70°		42.75	32.14	0.75	2.27	50.50	18.9
85°		39.10	30.16	0.77	2.54	47.79	15.4
100°		35.44	28.30	0.80	2.82	45.08	12.6

HEATING EFT Range (Standard) 25°F to 80°F

Entering Fluid Temp. (°F)	Entering Air Temp. (°F)	Total Capacity (MBtuH)	Power Input (kW)	Heat of Abs. (MBtuH)	COP
50°	60°	37.90	2.42	29.63	4.6
60°		42.26	2.55	33.56	4.9
70°		46.61	2.67	37.49	5.1
80°		50.97	2.80	41.42	5.3
50°		70°	35.84	2.47	27.42
60°	39.96		2.59	31.11	4.5
70°	44.07		2.72	34.79	4.7
80°	48.19		2.85	38.47	5.0
50°	80°		33.42	2.52	24.82
60°		37.26	2.65	28.21	4.1
70°		41.09	2.78	31.60	4.3
80°		44.92	2.91	34.99	4.5

LOW TEMP HEATING

Antifreeze Required

25°	60°	26.48	2.11	19.27	3.7
30°		28.62	2.18	21.20	3.9
40°		32.89	2.30	25.04	4.2
25°	70°	25.05	2.15	17.72	3.4
30°		27.07	2.21	19.52	3.6
40°		31.11	2.34	23.12	3.9
25°	80°	23.38	2.20	15.88	3.1
30°		25.25	2.26	17.54	3.3
40°		29.01	2.39	20.85	3.6

Units are complete packages containing compressor, reversing valve, expansion valve metering device, ECM fan motor and heat exchangers. Also included are safety controls: Overload protection for motors, high and low refrigerant pressure switches and solid state lock-out circuit. Optional UL approved internal electric heater, factory installed with primary thermal overload protection and magnetic contactors (208/230-1-60 only) optional UL approved internal Heat Recovery Package and/or Ground Loop Pump with purge connections available

Performance based on ARI/ISO rated air flow, fluid flow and voltage. For conditions other than rated, consult the FHP EAD selection software. Due to variations in installation actual performance may vary marginally from tabulated values.

As a result of continuing research and development, specifications are subject to change without notice.
ES035.2IP60 Rev: 7-03

FHP MANUFACTURING COMPANY

601 N.W. 65th Court - Fort Lauderdale, FL 33309

Phone: (954) 776-5471 - Fax: (800) 776-5529

<http://www.fhp-mfg.com>



PACKAGED UNITS SPECIFICATION DATA SHEET

FHP MANUFACTURING HIGH-EFFICIENCY WATER SOURCE HEAT PUMPS

ES049

ENVIROSAVER

ELECTRICAL SPECIFICATIONS

Electrical Characteristics	Elect. Symbol	Compressor		Blower		Loop Pump		Min. Circuit Amps	Max. Fuse/Breaker
		RLA	LRA	FLA	HP	FLA	HP		
208/230-1-60	-1	21.2	96.0	6.8	3/4	-	-	35.1	50
208/230-3-60	-3	15.0	88.0	6.8	3/4	-	-	27.3	40
460-3-60	-4	7.1	41.0	5.5	3/4	-	-	14.4	20

Note: 460 Volt Units (-4) Require Both Ground and Neutral Wires

MECHANICAL SPECIFICATIONS

Refrigerant: R-410A			
Air Coil			
Square Feet	Rows Deep	Tube O.D.	Fins/Inch
4.5	3	3/8	14
Water Coil			
Type	Work Press		
Coaxial	450 psig		
Blower Size	Compr Type		
10x 8 DD	Scroll		
Net Weight	Ship Weight		
318 lbs	348 lbs		

BLOWER PERFORMANCE

Available External Static Pressure (Inches of Water, Gauge. Wet Coil and Filter Included)												
Blower Speed	0.10	0.20	0.30	0.40	0.50	0.60	0.70	0.80	0.90	1.00	1.10	1.20
+						1150						
Norm						1000						
-						850						



FLUID PRESSURE DROP

Fluid Flow (GPM)	Pressure Drop	
	(FOH)	(PSIG)
6.0	2.9	1.27
7.0	3.9	1.67
9.5	6.7	2.90
12.0	10.2	4.42
16.0	17.1	7.41

ISO 13256-1 CERTIFIED PERFORMANCE DATA Rated at 1000 CFM and 12.0 GPM

Water Loop				Ground Water				Ground Loop			
Cooling		Heating		Cooling		Heating		Cooling		Heating	
Capacity	EER	Capacity	COP	Capacity	EER	Capacity	COP	Capacity	EER	Capacity	COP
34,000	16.0	39,000	5.4	38,000	24.0	32,000	4.6	36,000	21.8	28,500	4.0

CAPACITY DATA - PART LOAD

COOLING All performance at 1000 CFM and 12.0 GPM EFT Range (Standard) 50°F to 100°F

Entering Fluid Temp. (°F)	Entering Air Temp. (°F)	Total Capacity (MBtuH)	Sensible Capacity (MBtuH)	Sensible to Total Ratio	Power Input (kW)	Heat of Reject (MBtuH)	EER
50°	70°db	33.66	22.07	0.66	1.32	38.17	25.5
60°		32.44	21.44	0.66	1.49	37.54	21.7
70°		31.21	20.89	0.67	1.67	36.90	18.7
85°		29.37	20.17	0.69	1.92	35.94	15.3
100°		27.53	19.56	0.71	2.18	34.98	12.6
50°	75°db	36.05	26.33	0.73	1.33	40.59	27.1
60°		34.74	25.58	0.74	1.50	39.86	23.1
70°		33.42	24.92	0.75	1.68	39.14	19.9
85°		31.45	24.07	0.77	1.94	38.06	16.2
100°		29.48	23.34	0.79	2.20	36.98	13.4
50°	80°db	39.54	29.04	0.73	1.34	44.11	29.5
60°		38.10	28.21	0.74	1.51	43.27	25.2
70°		36.66	27.49	0.75	1.69	42.42	21.7
85°		34.50	26.55	0.77	1.95	41.16	17.7
100°		32.34	25.75	0.80	2.21	39.89	14.6
50°	85°db	43.03	31.77	0.74	1.35	47.64	31.9
60°		41.46	30.87	0.74	1.53	46.67	27.2
70°		39.90	30.08	0.75	1.70	45.71	23.4
85°		37.55	29.05	0.77	1.97	44.26	19.1
100°		35.20	28.18	0.80	2.23	42.81	15.8

HEATING EFT Range (Standard) 25°F to 80°F

Entering Fluid Temp. (°F)	Entering Air Temp. (°F)	Total Capacity (MBtuH)	Power Input (kW)	Heat of Abs. (MBtuH)	COP
50°	60°	34.88	2.02	27.98	5.1
60°		37.93	2.04	30.97	5.4
70°		40.98	2.06	33.95	5.8
80°		44.02	2.08	36.94	6.2
50°		70°	32.96	2.06	25.94
60°	35.84		2.08	28.75	5.1
70°	38.72		2.10	31.57	5.4
80°	41.60		2.12	34.38	5.8
50°	80°		30.71	2.10	23.53
60°		33.40	2.12	26.15	4.6
70°		36.08	2.14	28.76	4.9
80°		38.76	2.16	31.38	5.2

LOW TEMP HEATING

Antifreeze Required

25°	60°	26.72	1.97	19.99	4.0
30°		28.22	1.98	21.45	4.2
40°		31.20	2.00	24.37	4.6
25°	70°	25.26	2.01	18.40	3.7
30°		26.67	2.02	19.78	3.9
40°		29.49	2.04	22.53	4.2
25°	80°	23.53	2.06	16.52	3.4
30°		24.85	2.07	17.80	3.5
40°		27.48	2.08	20.36	3.9

Units are complete packages containing compressor, reversing valve, expansion valve metering device, ECM fan motor and heat exchangers. Also included are safety controls: Overload protection for motors, high and low refrigerant pressure switches and solid state lock-out circuit. Optional UL approved internal electric heater, factory installed with primary thermal overload protection and magnetic contactors (208/230-1-60 only) optional UL approved internal Heat Recovery Package and/or Ground Loop Pump with purge connections available

Performance based on ARI/ISO rated air flow, fluid flow and voltage. For conditions other than rated, consult the FHP EAD selection software. Due to variations in installation actual performance may vary marginally from tabulated values.

As a result of continuing research and development, specifications are subject to change without notice.
ES049.1IP60 Rev: 10-06

FHP MANUFACTURING COMPANY

601 N.W. 65th Court - Fort Lauderdale, FL 33309

Phone: (954) 776-5471 - Fax: (800) 776-5529

<http://www.fhp-mfg.com>



PACKAGED UNITS SPECIFICATION DATA SHEET

FHP MANUFACTURING HIGH-EFFICIENCY WATER SOURCE HEAT PUMPS

ES049

ENVIROSAVER

ELECTRICAL SPECIFICATIONS

Electrical Characteristics	Elect. Symbol	Compressor		Blower		Loop Pump		Min. Circuit Amps	Max. Fuse/Breaker
		RLA	LRA	FLA	HP	FLA	HP		
208/230-1-60	-1	21.2	96.0	6.8	3/4	-	-	35.1	50
208/230-3-60	-3	15.0	88.0	6.8	3/4	-	-	27.3	40
460-3-60	-4	7.1	41.0	5.5	3/4	-	-	14.4	20

Note: 460 Volt Units (-4) Require Both Ground and Neutral Wires

MECHANICAL SPECIFICATIONS

Refrigerant: R-410A			
Air Coil			
Square Feet	Rows Deep	Tube O.D.	Fins/Inch
4.5	3	3/8	14
Water Coil			
Type	Work Press		
Coaxial	450 psig		
Blower Size	Compr Type		
10x 8 DD	Scroll		
Net Weight	Ship Weight		
318 lbs	348 lbs		

BLOWER PERFORMANCE

Available External Static Pressure (Inches of Water, Gauge. Wet Coil and Filter Included)												
Blower Speed	0.10	0.20	0.30	0.40	0.50	0.60	0.70	0.80	0.90	1.00	1.10	1.20
+						1840						
Norm						1600						
-						1360						



FLUID PRESSURE DROP

Fluid Flow (GPM)	Pressure Drop	
	(FOH)	(PSIG)
6.0	2.9	1.27
7.0	3.9	1.67
9.5	6.7	2.90
12.0	10.2	4.42
16.0	17.1	7.41

ISO 13256-1 CERTIFIED PERFORMANCE DATA Rated at 1600 CFM and 12.0 GPM

Water Loop				Ground Water				Ground Loop			
Cooling		Heating		Cooling		Heating		Cooling		Heating	
Capacity	EER	Capacity	COP	Capacity	EER	Capacity	COP	Capacity	EER	Capacity	COP
48,000	13.5	58,000	4.8	54,000	19.0	48,000	4.2	49,000	15.5	38,000	3.6

CAPACITY DATA - FULL LOAD

COOLING All performance at 1600 CFM and 12.0 GPM EFT Range (Standard) 50°F to 100°F

Entering Fluid Temp. (°F)	Entering Air Temp. (°F)	Total Capacity (MBtuH)	Sensible Capacity (MBtuH)	Sensible to Total Ratio	Power Input (kW)	Heat of Reject (MBtuH)	EER
50°	70°db	47.65	31.22	0.66	2.56	56.38	18.6
60°		45.68	30.18	0.66	2.80	55.24	16.3
70°		43.70	29.23	0.67	3.05	54.09	14.3
85°		40.73	27.96	0.69	3.41	52.37	11.9
100°		37.77	26.83	0.71	3.78	50.66	10.0
50°	75°db	51.03	37.26	0.73	2.57	59.81	19.8
60°		48.92	36.01	0.74	2.82	58.53	17.4
70°		46.80	34.88	0.75	3.06	57.25	15.3
85°		43.62	33.37	0.77	3.43	55.33	12.7
100°		40.45	32.02	0.79	3.80	53.41	10.6
50°	80°db	55.97	41.10	0.73	2.59	64.83	21.6
60°		53.65	39.72	0.74	2.84	63.35	18.9
70°		51.33	38.48	0.75	3.09	61.87	16.6
85°		47.86	36.82	0.77	3.46	59.66	13.8
100°		44.38	35.32	0.80	3.83	57.44	11.6
50°	85°db	60.92	44.97	0.74	2.61	69.84	23.3
60°		58.39	43.47	0.74	2.86	68.17	20.4
70°		55.87	42.11	0.75	3.11	66.50	17.9
85°		52.09	40.29	0.77	3.49	63.99	14.9
100°		48.30	38.66	0.80	3.86	61.48	12.5

Units are complete packages containing compressor, reversing valve, expansion valve metering device, ECM fan motor and heat exchangers. Also included are safety controls: Overload protection for motors, high and low refrigerant pressure switches and solid state lock-out circuit. Optional UL approved internal electric heater, factory installed with primary thermal overload protection and magnetic contactors (208/230-1-60 only) optional UL approved internal Heat Recovery Package and/or Ground Loop Pump with purge connections available

Performance based on ARI/ISO rated air flow, fluid flow and voltage. For conditions other than rated, consult the FHP EAD selection software. Due to variations in installation actual performance may vary marginally from tabulated values.

As a result of continuing research and development, specifications are subject to change without notice.
ES049.2IP60 Rev: 10-06

HEATING EFT Range (Standard) 25°F to 80°F

Entering Fluid Temp. (°F)	Entering Air Temp. (°F)	Total Capacity (MBtuH)	Power Input (kW)	Heat of Abs. (MBtuH)	COP
50°	60°	50.51	3.28	39.32	4.5
60°		56.32	3.42	44.65	4.8
70°		62.12	3.56	49.99	5.1
80°		67.93	3.70	55.32	5.4
50°		70°	47.74	3.34	36.34
60°	53.22		3.48	41.34	4.5
70°	58.71		3.62	46.35	4.7
80°	64.20		3.76	51.35	5.0
50°	80°		44.48	3.41	32.82
60°		49.59	3.56	37.44	4.1
70°		54.70	3.70	42.05	4.3
80°		59.81	3.85	46.67	4.6

LOW TEMP HEATING

Antifreeze Required

25°	60°	35.28	2.93	25.28	3.5
30°		38.13	3.00	27.89	3.7
40°		43.82	3.14	33.11	4.1
25°	70°	33.35	2.99	23.16	3.3
30°		36.04	3.06	25.61	3.5
40°		41.42	3.20	30.51	3.8
25°	80°	31.08	3.05	20.67	3.0
30°		33.59	3.12	22.92	3.1
40°		38.60	3.27	27.44	3.5

FHP MANUFACTURING COMPANY

601 N.W. 65th Court - Fort Lauderdale, FL 33309

Phone: (954) 776-5471 - Fax: (800) 776-5529

<http://www.fhp-mfg.com>



PACKAGED UNITS SPECIFICATION DATA SHEET

FHP MANUFACTURING HIGH-EFFICIENCY WATER SOURCE HEAT PUMPS

ES061

ENVIROSAVER

ELECTRICAL SPECIFICATIONS

Electrical Characteristics	Elect. Symbol	Compressor		Blower		Loop Pump		Min. Circuit Amps	Max. Fuse/Breaker
		RLA	LRA	FLA	HP	FLA	HP		
208/230-1-60	-1	25.7	118.0	6.8	3/4	-	-	41.0	60
208/230-3-60	-3	19.6	123.0	6.8	3/4	-	-	33.1	50
460-3-60	-4	10.0	62.0	5.5	3/4	-	-	18.0	25

Note: 460 Volt Units (-4) Require Both Ground and Neutral Wires

MECHANICAL SPECIFICATIONS

Refrigerant: R-410A			
Air Coil			
Square Feet	Rows Deep	Tube O.D.	Fins/Inch
4.5	3	3/8	14
Water Coil			
Type	Work Press		
Coaxial	450 psig		
Blower Size	Compr Type		
11x 9 DD	Scroll		
Net Weight	Ship Weight		
390 lbs	415 lbs		

BLOWER PERFORMANCE

Available External Static Pressure (Inches of Water, Gauge. Wet Coil and Filter Included)												
Blower Speed	0.10	0.20	0.30	0.40	0.50	0.60	0.70	0.80	0.90	1.00	1.10	1.20
+						1600						
Norm						1400						
-						1200						



FLUID PRESSURE DROP

Fluid Flow (GPM)	Pressure Drop	
	(FOH)	(PSIG)
8	3.5	1.51
12	7.2	3.13
16	12.1	5.25
18	15.0	6.49
22	21.5	9.32

ISO 13256-1 CERTIFIED PERFORMANCE DATA Rated at 1400 CFM and 14.0 GPM

Water Loop				Ground Water				Ground Loop			
Cooling		Heating		Cooling		Heating		Cooling		Heating	
Capacity	EER	Capacity	COP	Capacity	EER	Capacity	COP	Capacity	EER	Capacity	COP
42,000	17.0	48,000	5.4	48,000	26.0	40,000	4.6	45,000	23.5	36,500	4.0

CAPACITY DATA - PART LOAD

COOLING All performance at 1400 CFM and 14.0 GPM EFT Range (Standard) 50°F to 100°F

Entering Fluid Temp. (°F)	Entering Air Temp. (°F)	Total Capacity (MBtuH)	Sensible Capacity (MBtuH)	Sensible to Total Ratio	Power Input (kW)	Heat of Reject (MBtuH)	EER
50°	70°db	42.78	27.69	0.65	1.56	48.12	27.4
60°		40.94	26.72	0.65	1.76	46.95	23.3
70°		39.10	25.84	0.66	1.96	45.79	20.0
85°		36.34	24.64	0.68	2.26	44.04	16.1
100°		33.58	23.56	0.70	2.55	42.29	13.2
50°	75°db	45.82	33.04	0.72	1.57	51.18	29.2
60°		43.85	31.89	0.73	1.77	49.89	24.8
70°		41.88	30.83	0.74	1.97	48.60	21.3
85°		38.92	29.41	0.76	2.27	46.67	17.2
100°		35.97	28.12	0.78	2.57	44.73	14.0
50°	80°db	50.26	36.45	0.73	1.58	55.66	31.7
60°		48.10	35.17	0.73	1.79	54.19	26.9
70°		45.94	34.01	0.74	1.99	52.71	23.1
85°		42.70	32.44	0.76	2.29	50.50	18.7
100°		39.46	31.02	0.79	2.59	48.29	15.2
50°	85°db	54.69	39.88	0.73	1.60	60.14	34.3
60°		52.34	38.49	0.74	1.80	58.48	29.1
70°		49.99	37.22	0.74	2.00	56.83	25.0
85°		46.47	35.51	0.76	2.31	54.34	20.2
100°		42.95	33.95	0.79	2.61	51.85	16.5

Units are complete packages containing compressor, reversing valve, expansion valve metering device, ECM fan motor and heat exchangers. Also included are safety controls: Overload protection for motors, high and low refrigerant pressure switches and solid state lock-out circuit. Optional UL approved internal electric heater, factory installed with primary thermal overload protection and magnetic contactors (208/230-1-60 only) optional UL approved internal Heat Recovery Package and/or Ground Loop Pump with purge connections available

Performance based on ARI/ISO rated air flow, fluid flow and voltage. For conditions other than rated, consult the FHP EAD selection software. Due to variations in installation actual performance may vary marginally from tabulated values.

As a result of continuing research and development, specifications are subject to change without notice.
ES061.1IP60 Rev: 10-06

HEATING EFT Range (Standard) 25°F to 80°F

Entering Fluid Temp. (°F)	Entering Air Temp. (°F)	Total Capacity (MBtuH)	Power Input (kW)	Heat of Abs. (MBtuH)	COP
50°	60°	43.50	2.54	34.82	5.0
60°		46.98	2.55	38.29	5.4
70°		50.47	2.55	41.75	5.8
80°		53.95	2.56	45.22	6.2
50°		70°	41.11	2.59	32.27
60°	44.40		2.60	35.55	5.0
70°	47.69		2.60	38.82	5.4
80°	50.99		2.61	42.09	5.7
50°	80°		38.31	2.65	29.27
60°		41.37	2.65	32.32	4.6
70°		44.44	2.66	35.36	4.9
80°		47.50	2.66	38.41	5.2

LOW TEMP HEATING

Antifreeze Required

25°	60°	34.10	2.53	25.47	4.0
30°		35.81	2.53	27.17	4.1
40°		39.23	2.54	30.57	4.5
25°	70°	32.24	2.58	23.44	3.7
30°		33.85	2.58	25.05	3.8
40°		37.08	2.58	28.26	4.2
25°	80°	30.04	2.63	21.05	3.3
30°		31.54	2.64	22.54	3.5
40°		34.55	2.64	25.53	3.8

FHP MANUFACTURING COMPANY

601 N.W. 65th Court - Fort Lauderdale, FL 33309

Phone: (954) 776-5471 - Fax: (800) 776-5529

<http://www.fhp-mfg.com>



PACKAGED UNITS SPECIFICATION DATA SHEET

FHP MANUFACTURING HIGH-EFFICIENCY WATER SOURCE HEAT PUMPS

ES061

ENVIROSAVER

ELECTRICAL SPECIFICATIONS

Electrical Characteristics	Elect. Symbol	Compressor		Blower		Loop Pump		Min. Circuit Amps	Max. Fuse/Breaker
		RLA	LRA	FLA	HP	FLA	HP		
208/230-1-60	-1	25.7	118.0	6.8	3/4	-	-	41.0	60
208/230-3-60	-3	19.6	123.0	6.8	3/4	-	-	33.1	50
460-3-60	-4	10.0	62.0	5.5	3/4	-	-	18.0	25

Note: 460 Volt Units (-4) Require Both Ground and Neutral Wires

MECHANICAL SPECIFICATIONS

Refrigerant: R-410A			
Air Coil			
Square Feet	Rows Deep	Tube O.D.	Fins/Inch
4.5	3	3/8	14
Water Coil			
Type	Work Press		
Coaxial	450 psig		
Blower Size	Compr Type		
11x 9 DD	Scroll		
Net Weight	Ship Weight		
390 lbs	415 lbs		

BLOWER PERFORMANCE

Available External Static Pressure (Inches of Water, Gauge. Wet Coil and Filter Included)												
Blower Speed	0.10	0.20	0.30	0.40	0.50	0.60	0.70	0.80	0.90	1.00	1.10	1.20
+						2200						
Norm						2000						
-						1700						



ISO 13256-1 CERTIFIED PERFORMANCE DATA Rated at 2000 CFM and 14.0 GPM

Water Loop				Ground Water				Ground Loop			
Cooling		Heating		Cooling		Heating		Cooling		Heating	
Capacity	EER	Capacity	COP	Capacity	EER	Capacity	COP	Capacity	EER	Capacity	COP
60,000	14.0	72,000	4.7	68,000	19.7	61,000	4.3	62,000	15.7	49,000	3.6

FLUID PRESSURE DROP

Fluid Flow (GPM)	Pressure Drop	
	(FOH)	(PSIG)
8	3.5	1.51
12	7.2	3.13
16	12.1	5.25
18	15.0	6.49
22	21.5	9.32

CAPACITY DATA - FULL LOAD

COOLING All performance at 2000 CFM and 14.0 GPM EFT Range (Standard) 50°F to 100°F

Entering Fluid Temp. (°F)	Entering Air Temp. (°F)	Total Capacity (MBtuH)	Sensible Capacity (MBtuH)	Sensible to Total Ratio	Power Input (kW)	Heat of Reject (MBtuH)	EER
50°	70°db 61°wb	60.21	38.97	0.65	3.15	70.96	19.1
60°		57.62	37.60	0.65	3.44	69.37	16.7
70°		55.03	36.36	0.66	3.74	67.78	14.7
85°		51.14	34.68	0.68	4.18	65.40	12.2
100°		47.26	33.15	0.70	4.62	63.02	10.2
50°	75°db 63°wb	64.48	46.50	0.72	3.17	75.29	20.4
60°		61.71	44.87	0.73	3.46	73.52	17.8
70°		58.93	43.39	0.74	3.76	71.76	15.7
85°		54.77	41.39	0.76	4.20	69.11	13.0
100°		50.61	39.57	0.78	4.65	66.47	10.9
50°	80°db 67°wb	70.72	51.29	0.73	3.19	81.62	22.2
60°		67.68	49.49	0.73	3.49	79.60	19.4
70°		64.64	47.86	0.74	3.79	77.58	17.1
85°		60.08	45.65	0.76	4.24	74.54	14.2
100°		55.52	43.66	0.79	4.68	71.51	11.9
50°	85°db 71°wb	76.97	56.12	0.73	3.22	87.95	23.9
60°		73.66	54.16	0.74	3.52	85.67	20.9
70°		70.36	52.38	0.74	3.82	83.39	18.4
85°		65.40	49.97	0.76	4.27	79.97	15.3
100°		60.44	47.78	0.79	4.72	76.55	12.8

HEATING EFT Range (Standard) 25°F to 80°F

Entering Fluid Temp. (°F)	Entering Air Temp. (°F)	Total Capacity (MBtuH)	Power Input (kW)	Heat of Abs. (MBtuH)	COP
50°	60°	63.83	4.16	49.63	4.5
60°		70.51	4.32	55.77	4.8
70°		77.19	4.48	61.91	5.1
80°		83.87	4.64	68.05	5.3
50°		70°	60.33	4.24	45.86
60°	66.64		4.40	51.62	4.4
70°	72.95		4.56	57.38	4.7
80°	79.26		4.72	63.14	4.9
50°	80°		56.21	4.33	41.42
60°		62.09	4.50	46.73	4.0
70°		67.97	4.66	52.05	4.3
80°		73.84	4.83	57.36	4.5

LOW TEMP HEATING

Antifreeze Required

25°	60°	46.21	3.76	33.36	3.6
30°		49.48	3.84	36.37	3.8
40°		56.03	4.00	42.37	4.1
25°	70°	43.68	3.83	30.59	3.3
30°		46.77	3.92	33.41	3.5
40°		52.96	4.08	39.04	3.8
25°	80°	40.71	3.92	27.32	3.0
30°		43.59	4.00	29.92	3.2
40°		49.35	4.17	35.12	3.5

Units are complete packages containing compressor, reversing valve, expansion valve metering device, ECM fan motor and heat exchangers. Also included are safety controls: Overload protection for motors, high and low refrigerant pressure switches and solid state lock-out circuit. Optional UL approved internal electric heater, factory installed with primary thermal overload protection and magnetic contactors (208/230-1-60 only) optional UL approved internal Heat Recovery Package and/or Ground Loop Pump with purge connections available

Performance based on ARI/ISO rated air flow, fluid flow and voltage. For conditions other than rated, consult the FHP EAD selection software. Due to variations in installation actual performance may vary marginally from tabulated values.

As a result of continuing research and development, specifications are subject to change without notice.
ES061.2IP60 Rev: 10-06

FHP MANUFACTURING COMPANY

601 N.W. 65th Court - Fort Lauderdale, FL 33309

Phone: (954) 776-5471 - Fax: (800) 776-5529

<http://www.fhp-mfg.com>



PACKAGED UNITS SPECIFICATION DATA SHEET

FHP MANUFACTURING HIGH-EFFICIENCY WATER SOURCE HEAT PUMPS

ES071

ENVIROSAVER

ELECTRICAL SPECIFICATIONS

Electrical Characteristics	Elect. Symbol	Compressor		Blower		Loop Pump		Min. Circuit Amps	Max. Fuse/Breaker
		RLA	LRA	FLA	HP	FLA	HP		
208/230-1-60	-1	29.9	150.0	7.0	1	-	-	46.2	70

MECHANICAL SPECIFICATIONS

Refrigerant: R-410A			
Air Coil			
Square Feet	Rows Deep	Tube O.D.	Fins/Inch
6.0	3	3/8	14
Water Coil			
Type	Work Press		
Coaxial	450 psig		
Blower Size	Compr Type		
12 x 9 DD	Scroll		
Net Weight	Ship Weight		
450 lbs	495 lbs		

BLOWER PERFORMANCE

Available External Static Pressure (Inches of Water, Gauge. Wet Coil and Filter Included)												
Blower Speed	0.10	0.20	0.30	0.40	0.50	0.60	0.70	0.80	0.90	1.00	1.10	1.20
+						1600						
Norm						1400						
-						1200						



ISO 13256-1 CERTIFIED PERFORMANCE DATA Rated at 1400 CFM and 18.0 GPM

Water Loop				Ground Water				Ground Loop			
Cooling		Heating		Cooling		Heating		Cooling		Heating	
Capacity	EER	Capacity	COP	Capacity	EER	Capacity	COP	Capacity	EER	Capacity	COP
51,000	15.8	55,000	4.4	57,000	25.2	47,000	4.0	56,000	21.8	42,000	3.6

FLUID PRESSURE DROP

Fluid Flow (GPM)	Pressure Drop	
	(FOH)	(PSIG)
8	3.5	1.5
12	7.2	3.1
16	12.1	5.3
18	15.0	6.5
22	21.5	9.3

CAPACITY DATA - PART LOAD

COOLING All performance at 1400 CFM and 18.0 GPM EFT Range (Standard) 50°F to 100°F

Entering Fluid Temp. (°F)	Entering Air Temp. (°F)	Total Capacity (MBtuH)	Sensible Capacity (MBtuH)	Sensible to Total Ratio	Power Input (kW)	Heat of Reject (MBtuH)	EER
50°	70°db 61°wb	50.33	32.44	0.64	1.90	56.82	26.5
60°		48.62	31.60	0.65	2.22	56.22	21.9
70°		46.92	30.88	0.66	2.55	55.61	18.4
85°		44.36	29.97	0.68	3.03	54.71	14.6
100°		41.81	29.23	0.70	3.52	53.80	11.9
50°	75°db 63°wb	53.92	38.78	0.72	1.91	60.45	28.2
60°		52.10	37.78	0.73	2.24	59.73	23.3
70°		50.27	36.92	0.73	2.56	59.02	19.6
85°		47.54	35.83	0.75	3.05	57.94	15.6
100°		44.80	34.95	0.78	3.53	56.87	12.7
50°	80°db 67°wb	59.18	42.81	0.72	1.93	65.76	30.7
60°		57.18	41.71	0.73	2.25	64.88	25.4
70°		55.18	40.76	0.74	2.58	63.99	21.4
85°		52.18	39.56	0.76	3.07	62.67	17.0
100°		49.18	38.59	0.78	3.56	61.34	13.8
50°	85°db 71°wb	64.44	46.89	0.73	1.94	71.07	33.2
60°		62.27	45.69	0.73	2.27	70.02	27.4
70°		60.09	44.64	0.74	2.60	68.97	23.1
85°		56.83	43.33	0.76	3.10	67.39	18.4
100°		53.56	42.27	0.79	3.59	65.82	14.9

HEATING EFT Range (Standard) 25°F to 80°F

Entering Fluid Temp. (°F)	Entering Air Temp. (°F)	Total Capacity (MBtuH)	Power Input (kW)	Heat of Abs. (MBtuH)	COP
50°	60°	50.90	3.48	39.03	4.3
60°		54.67	3.56	42.51	4.5
70°		58.45	3.65	46.00	4.7
80°		62.22	3.73	49.48	4.9
50°		70°	48.13	3.54	36.04
60°	51.69		3.63	39.31	4.2
70°	55.26		3.71	42.58	4.4
80°	58.83		3.80	45.85	4.5
50°	80°		44.87	3.62	32.52
60°		48.19	3.71	35.54	3.8
70°		51.51	3.80	38.56	4.0
80°		54.83	3.88	41.58	4.1

LOW TEMP HEATING

Antifreeze Required

25°	60°	40.65	3.26	29.51	3.6
30°		42.50	3.31	31.21	3.8
40°		46.20	3.39	34.62	4.0
25°	70°	38.44	3.32	27.10	3.4
30°		40.19	3.37	28.70	3.5
40°		43.69	3.45	31.90	3.7
25°	80°	35.85	3.40	24.26	3.1
30°		37.48	3.44	25.74	3.2
40°		40.73	3.53	28.69	3.4

Units are complete packages containing compressor, reversing valve, expansion valve metering device, ECM fan motor and heat exchangers. Also included are safety controls: Overload protection for motors, high and low refrigerant pressure switches and solid state lock-out circuit. Optional UL approved internal electric heater, factory installed with primary thermal overload protection and magnetic contactors (208/230-1-60 only) optional UL approved internal Heat Recovery Package and/or Ground Loop Pump with purge connections available

Performance based on ARI/ISO rated air flow, fluid flow and voltage. For conditions other than rated, consult the FHP EAD selection software. Due to variations in installation actual performance may vary marginally from tabulated values.

As a result of continuing research and development, specifications are subject to change without notice.
ES071.1IP60 Rev:10-06

FHP MANUFACTURING COMPANY

601 N.W. 65th Court - Fort Lauderdale, FL 33309

Phone: (954) 776-5471 - Fax: (800) 776-5529

<http://www.fhp-mfg.com>



PACKAGED UNITS SPECIFICATION DATA SHEET

FHP MANUFACTURING HIGH-EFFICIENCY WATER SOURCE HEAT PUMPS

ES071

ENVIROSAVER

ELECTRICAL SPECIFICATIONS

Electrical Characteristics	Elect. Symbol	Compressor		Blower		Loop Pump		Min. Circuit Amps	Max. Fuse/Breaker
		RLA	LRA	FLA	HP	FLA	HP		
208/230-1-60	-1	29.9	150.0	7.0	1	-	-	46.2	70

MECHANICAL SPECIFICATIONS

Refrigerant: R-410A			
Air Coil			
Square Feet	Rows Deep	Tube O.D.	Fins/Inch
6.0	3	3/8	14
Water Coil			
Type	Work Press		
Coaxial	450 psig		
Blower Size	Compr Type		
12x 9 DD	Scroll		
Net Weight	Ship Weight		
450 lbs	495 lbs		

BLOWER PERFORMANCE

Available External Static Pressure (Inches of Water, Gauge. Wet Coil and Filter Included)												
Blower Speed	0.10	0.20	0.30	0.40	0.50	0.60	0.70	0.80	0.90	1.00	1.10	1.20
+						2300						
Norm						2200						
-						1900						



ISO 13256-1 CERTIFIED PERFORMANCE DATA Rated at 2200 CFM and 18.0 GPM

Water Loop				Ground Water				Ground Loop			
Cooling		Heating		Cooling		Heating		Cooling		Heating	
Capacity	EER	Capacity	COP	Capacity	EER	Capacity	COP	Capacity	EER	Capacity	COP
72,000	14.5	80,000	4.5	77,000	19.6	68,000	4.2	74,000	16.3	53,000	3.7

FLUID PRESSURE DROP

Fluid Flow (GPM)	Pressure Drop	
	(FOH)	(PSIG)
8	3.5	1.5
12	7.2	3.1
16	12.1	5.3
18	15.0	6.5
22	21.5	9.3

CAPACITY DATA - FULL LOAD

COOLING All performance at 2200 CFM and 18.0 GPM EFT Range (Standard) 50°F to 100°F

Entering Fluid Temp. (°F)	Entering Air Temp. (°F)	Total Capacity (MBtuH)	Sensible Capacity (MBtuH)	Sensible to Total Ratio	Power Input (kW)	Heat of Reject (MBtuH)	EER
50°	70°db 61°wb	66.48	42.79	0.64	3.67	79.02	18.1
60°		64.92	42.13	0.65	4.04	78.70	16.1
70°		63.35	41.63	0.66	4.41	78.38	14.4
85°		61.00	41.15	0.67	4.95	77.90	12.3
100°		58.64	40.96	0.70	5.50	77.42	10.7
50°	75°db 63°wb	71.25	51.19	0.72	3.69	83.85	19.3
60°		69.57	50.41	0.72	4.06	83.43	17.1
70°		67.89	49.81	0.73	4.43	83.01	15.3
85°		65.37	49.24	0.75	4.98	82.37	13.1
100°		62.85	49.01	0.78	5.53	81.74	11.4
50°	80°db 67°wb	78.21	56.53	0.72	3.72	90.92	21.0
60°		76.37	55.67	0.73	4.09	90.34	18.7
70°		74.53	55.01	0.74	4.46	89.77	16.7
85°		71.77	54.38	0.76	5.02	88.91	14.3
100°		69.01	54.13	0.78	5.58	88.04	12.4
50°	85°db 71°wb	85.18	61.93	0.73	3.75	97.98	22.7
60°		83.18	60.98	0.73	4.12	97.25	20.2
70°		81.17	60.27	0.74	4.50	96.53	18.0
85°		78.17	59.58	0.76	5.06	95.44	15.5
100°		75.17	59.30	0.79	5.62	94.35	13.4

HEATING EFT Range (Standard) 25°F to 80°F

Entering Fluid Temp. (°F)	Entering Air Temp. (°F)	Total Capacity (MBtuH)	Power Input (kW)	Heat of Abs. (MBtuH)	COP
50°	60°	71.17	4.78	54.85	4.4
60°		79.01	5.08	61.67	4.6
70°		86.86	5.38	68.48	4.7
80°		94.70	5.68	75.30	4.9
50°		70°	67.30	4.87	50.69
60°	74.71		5.17	57.05	4.2
70°	82.12		5.48	63.42	4.4
80°	89.53		5.79	69.78	4.5
50°	80°		62.76	4.98	45.78
60°		69.66	5.29	51.61	3.9
70°		76.56	5.60	57.44	4.0
80°		83.45	5.91	63.28	4.1

LOW TEMP HEATING

Antifreeze Required

25°	60°	50.56	4.04	36.79	3.7
30°		54.41	4.19	40.12	3.8
40°		62.09	4.48	46.79	4.1
25°	70°	47.83	4.11	33.81	3.4
30°		51.46	4.26	36.92	3.5
40°		58.72	4.56	43.14	3.8
25°	80°	44.62	4.19	30.30	3.1
30°		48.00	4.35	33.15	3.2
40°		54.77	4.66	38.85	3.4

Units are complete packages containing compressor, reversing valve, expansion valve metering device, ECM fan motor and heat exchangers. Also included are safety controls: Overload protection for motors, high and low refrigerant pressure switches and solid state lock-out circuit. Optional UL approved internal electric heater, factory installed with primary thermal overload protection and magnetic contactors (208/230-1-60 only) optional UL approved internal Heat Recovery Package and/or Ground Loop Pump with purge connections available

Performance based on ARI/ISO rated air flow, fluid flow and voltage. For conditions other than rated, consult the FHP EAD selection software. Due to variations in installation actual performance may vary marginally from tabulated values.

As a result of continuing research and development, specifications are subject to change without notice.
ES071.2IP60 Rev: 1-06

FHP MANUFACTURING COMPANY

601 N.W. 65th Court - Fort Lauderdale, FL 33309

Phone: (954) 776-5471 - Fax: (800) 776-5529

<http://www.fhp-mfg.com>