



GUIDE SPECIFICATIONS

GT Series

GENERAL

Units shall be performance certified to ISO standard 13256-1 for Water Loop Heat Pump, Ground Water Heat Pump and Ground Loop Heat Pump applications. Units shall be Underwriter Laboratories (UL and ULc) listed for safety on all models. Each unit shall be run tested at the factory. Each unit shall be pallet mounted and stretch wrapped. The units shall be manufactured in an ISO 9001:2000 certified facility.

The units shall be warranted by the manufacturer against defects in materials and workmanship for a period of one year on all parts, and 5 years on the compressor.

The units shall be designed to operate with entering fluid temperatures between 50°F (10°C) and 110°F (43.3°C) in cooling and temperatures between 25°F (-3.9°C) and 80°F (27°C) in heating.

CASING & CABINET

The cabinet shall be fabricated from heavy-gauge steel finished with Galvalume® plus, an aluminum-zinc alloy with a clear acrylic coating, for additional corrosion protection. The interior shall be insulated with ½" (12.7mm) thick, multi density, coated, glass fiber. All units shall allow sufficient service access to replace the compressor without unit removal. One blower and two compressor compartment access panels shall be removable with supply and return ductwork in place. A duct collar shall be provided on the supply air opening. A filter rack with 1" (25.4mm) thick disposable filters and a 1" (25.4mm) return air duct collar shall be provided with each unit. The units shall have an insulated divider panel between the air handling section and the compressor section to minimize the transmission of compressor noise, and to permit service testing without air bypass. Units shall have a stainless steel condensate drain pan.

REFRIGERATION CIRCUITS

All units shall contain a sealed refrigerant circuit including a hermetic compressor, bi-directional thermal expansion valve metering device, finned tube air-to-refrigerant heat exchanger, refrigerant reversing valve and service ports. Compressor shall be high efficiency rotary or scroll type, designed for heat pump duty, quiet operation and mounted on rubber vibration isolators. Compressor motors shall be equipped with overload protection. Refrigerant reversing valves shall be pilot operated sliding piston type with replaceable encapsulated magnetic coils energized only during the cooling cycle. The finned tube coil shall be constructed of lanced aluminum fins not exceeding fourteen fins per inch bonded to rifled copper tubes in a staggered pattern not less than three rows deep and have a 450 PSIG (3100 kPa) working pressure. Coils shall have a baked polyester enamel coating for protection against most airborne chemicals. Coil end plates shall be aluminum. The coaxial water-to-refrigerant heat exchanger shall be constructed of a convoluted copper (optional cupronickel) inner tube and steel outer tube with a designed refrigerant working pressure of 450 PSIG (3100 kPa) and a designed water side working pressure of no less than 400 PSIG (2750 kPa). The water-to-refrigerant heat exchanger shall be insulated to prevent condensation at low fluid temperatures.

FAN MOTOR & ASSEMBLY

The fan shall be direct drive centrifugal forward curved type with a dynamically balanced wheel. The housing and wheel shall be designed for quiet low velocity operation and shall be provided with a removable inlet ring. The fan housing shall be removable from the unit without disconnecting the supply air ductwork for servicing of the fan motor. The fan motor shall be three speed PSC type for direct drive and single speed for belt drive units. The motor shall be permanently lubricated and have thermal overload protection.

ELECTRICAL

Controls and safety devices will be factory wired and mounted within the unit. Controls shall include fan relay, compressor contactor, 24V transformer, reversing valve coil and solid state lock-out controller (UPM). The UPM controller shall include the following features: Anti-short cycle time delay, random start, brown out/surge/power interruption protection, 90 second low pressure switch bypass timer, shutdown on high or low refrigerant pressure safety switch inputs, shutdown for the optional freezestat or high level condensate sensors, 24 VAC alarm output for remote fault indication, unit reset at thermostat or disconnect, ability to defeat time delays for servicing and automatic intelligent reset. The UPM shall automatically reset after a safety shut down and restart the unit, if the cause of the shut down no longer exists, after the anti-short cycle and random start timers expire. Should a fault re-occur within 10 minutes after reset, then a permanent lockout will occur. A light emitting diode (LED) shall annunciate the following alarms: high refrigerant pressure, low refrigerant pressure, low water temperature and a high level of condensate in the drain pan (when equipped with the optional low water temperature and high level condensate sensors). The LED will display each fault condition as soon as the fault occurs. If a permanent lockout occurs, then the fault LED will display the type of fault until the unit is reset.

Safety devices include a low pressure cutout set a 20 PSIG (140 kPa) for loss of charge protection (freezestat and/or high discharge gas temperature sensor is not acceptable) and a high pressure cutout control set at 380 PSIG (2600 kPa).

A terminal block with screw terminals shall be provided for control wiring. An optional energy management relay to allow unit control by an external source shall be factory installed.

PIPING

Supply, return water and condensate drain connections shall be brass female pipe thread fittings and mounted flush to cabinet exterior.

INTERNAL ELECTRIC HEAT

208/230-1-60 volt units shall be equipped with optional factory installed internal electric resistance heat for axillary and emergency heat. Electric heater must be Underwriter's Laboratories (UL and ULc) approved for safety when installed in the unit. External heater packages or heater packages not specifically listed for use with the unit are unacceptable. Electric heater packages shall include a heater collar mounted to the blower outlet, individual thermal overload protected heater elements no greater than 5kW each and magnetic contactors. Heater packages shall have a separate power supply connection from the compressor and this power supply shall also power the unit blower motor and control transformer for safe operation. Electrical heat option is not available with belt drive units.

HEAT RECOVERY PACKAGE

208/230 volt units shall be equipped with a optional factory installed internal heat recovery kit for domestic hot water production. This kit shall include an internally protected pump, double walled coaxial water-to-refrigerant heat exchanger, 140°F (60°C) hot water temperature limit switch and an on/off switch/circuit breaker.

LOOP PUMP PACKAGE - CONSULT FACTORY

208/230-1-60 volt units shall be equipped with an optional factory installed ground loop pump kit. This kit shall include a 1/6 HP loop pump, isolation valves and a set of purge connections for purging and pressurizing the ground loop with the unit in place. The pump, all piping and valves shall be internal to the unit.



FHP Manufacturing Co.
 601 N.W. 65th Court
 Fort Lauderdale, FL 33309
 Phone: (954) 776-5471
 Fax: (800) 776-5529
<http://www.fhp-mfg.com>

GT/GS Series Vertical Dimensions

MODEL	A	B	C	D	E	F	G	H	J	K	M	N	P	Q	Condenser Water Connections	Recommended Replacement Nominal Filter Size
	Width	Depth	Height								R/A Duct Flg Width	R/A Duct Flg Height	Filter Rack Height			
GT010	21.50	21.50	36.25	9.75	11.75	5.88	5.25	5.25	8.00	14.25	17.50	14.00	16.00	4.50	3/4" F.P.T.	16 X 20 X 1
GT/GS018	21.50	21.50	40.25	11.75	13.75	3.75	7.00	5.25	8.00	14.25	17.50	18.00	20.00	4.13	3/4" F.P.T.	20 X 20 X 1
GT/GS024	21.50	21.50	40.25	11.75	13.75	3.75	7.00	5.25	8.00	14.25	17.50	18.00	20.00	4.13	3/4" F.P.T.	20 X 20 X 1
GT/GS030, 036	21.50	26.00	47.25	13.75	15.75	6.13	5.25	5.25	8.00	15.25	22.00	22.00	24.00	4.00	3/4" F.P.T.	24 X 24 X 1
GT/GS042	24.00	32.75	47.25	15.75	15.75	8.38	4.75	5.25	8.00	16.25	28.00	22.00	24.00	3.50	1" F.P.T.	24 X 30 X 1
GT/GS048	24.00	32.75	47.25	15.75	15.75	8.38	5.50	5.25	8.00	16.25	28.00	22.00	24.00	4.00	1" F.P.T.	24 X 30 X 1
GT/GS054	26.00	33.25	51.25	17.75	17.75	7.75	4.25	5.25	8.00	18.50	28.00	22.00	24.00	4.00	1" F.P.T.	24 X 30 X 1
GT/GS062	26.00	33.25	51.25	17.75	17.75	7.13	6.25	5.25	8.00	18.50	28.00	22.00	24.00	4.00	1" F.P.T.	24 X 30 X 1
GT/GS070	26.00	33.25	58.25	17.75	17.75	7.13	6.25	5.25	8.00	18.50	28.00	30.00	32.00	4.00	1" F.P.T.	16 X 30 X 1 (2)

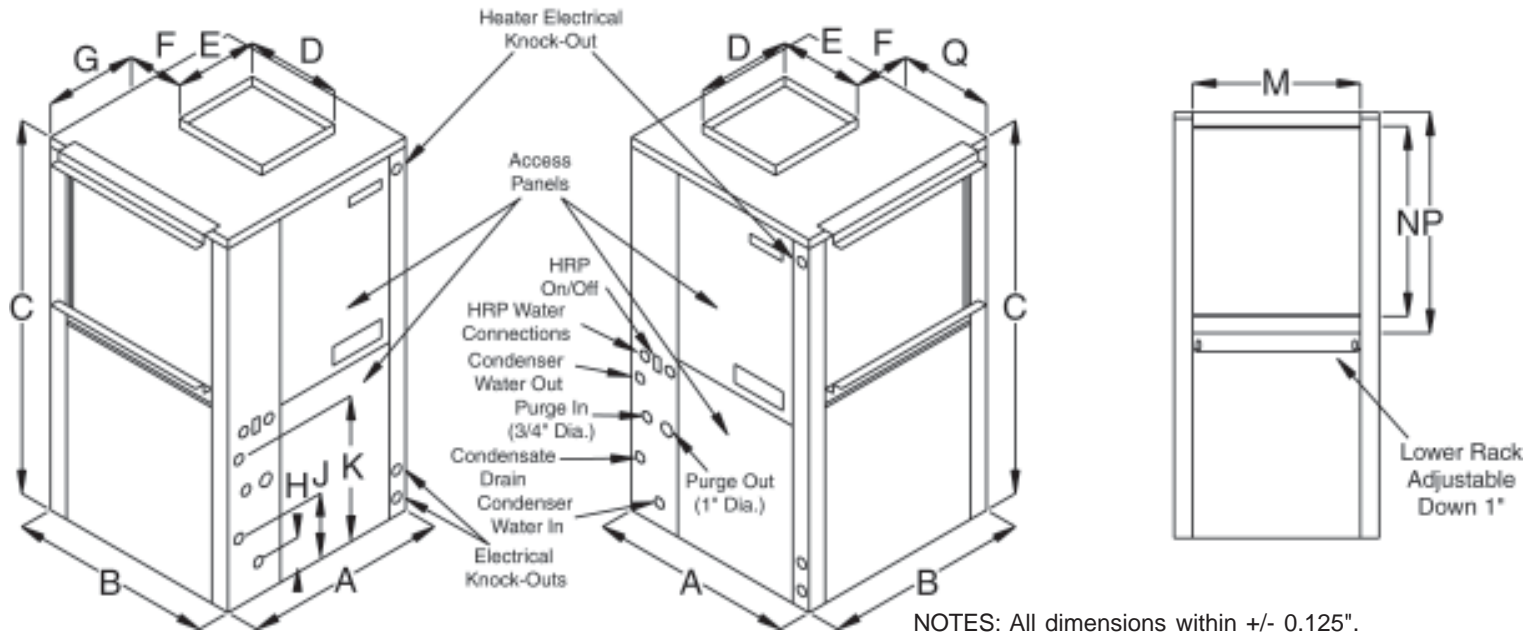

**Left Hand
Return
(FLT)**

**Right Hand
Return
(FRT)**

NOTES: All dimensions within +/- 0.125".

All condensate drain connections are 3/4" FPT.

All Heat Recovery Kit connections are 1/2" FPT.

Internal electric heat available on 208-230/1/60 top discharge units only

Internal Loop Pump available on 208-230 volt only.

Internal Heat Recovery Kit available on 208-230 volt only.

Specifications subject to change without notice.



FHP Manufacturing Co.
 601 N.W. 65th Court
 Fort Lauderdale, FL 33309
 Phone: (954) 776-5471
 Fax: (800) 776-5529
<http://www.fhp-mfg.com>

GT/GS Series Horizontal Dimensions

MODEL	A	B	C	D	E	F	G	H	J	K	M	N	P	Q	R	T	Condenser Water Connections	Recommended Replacement Nom. Filter Size
	Width	Depth	Height		R/A Duct Flg Width									Filter Rack Height	R/A Duct Flg Height			
GT010	25.50	43.00	21.75	2.00	17.50	23.50	5.25	14.25	7.88	9.75	0.75	11.75	5.88	0.25	20.50	18.50	3/4" F.P.T.	20 X 20 X 1
GT/GS018	25.50	45.00	21.75	2.00	19.25	23.75	5.25	14.25	4.31	11.75	5.00	13.75	4.31	5.00	20.50	18.50	3/4" F.P.T.	20 X 20 X 1
GT/GS024	25.50	43.00	21.75	2.00	20.00	21.00	5.25	14.25	4.31	11.75	5.00	13.75	4.31	5.00	20.50	18.50	3/4" F.P.T.	20 X 20 X 1
GT/GS030,036	26.00	54.50	21.75	2.00	30.00	22.50	5.25	15.25	4.50	13.75	3.00	15.75	4.50	3.00	20.50	18.50	3/4" F.P.T.	20 X 30 X 1 (2)
GT/GS042	30.00	68.00	21.75	2.50	33.50	32.00	5.25	16.25	5.81	15.75	3.00	15.75	5.81	3.00	20.50	18.50	1" F.P.T.	18 X 20 X 1 (2)
GT/GS048	30.00	68.00	21.75	2.50	33.50	32.00	5.25	16.25	5.81	15.75	3.00	15.75	5.81	3.00	20.50	18.50	1" F.P.T.	18 X 20 X 1 (2)
GT/GS054	30.00	68.00	21.75	2.50	33.50	32.00	5.25	18.50	4.81	17.75	2.00	17.75	4.81	2.00	20.50	18.50	1" F.P.T.	18 X 20 X 1 (2)
GT/GS062	30.00	68.00	21.75	2.50	33.50	32.00	5.25	18.50	7.66	17.75	2.00	17.75	7.66	2.00	20.50	18.50	1" F.P.T.	18 X 20 X 1 (2)
GT/GS070	30.00	78.00	21.75	2.50	44.00	31.50	5.25	18.50	7.66	17.75	2.00	17.75	7.66	2.00	20.50	18.50	1" F.P.T.	20 X 24 X 1 (2)

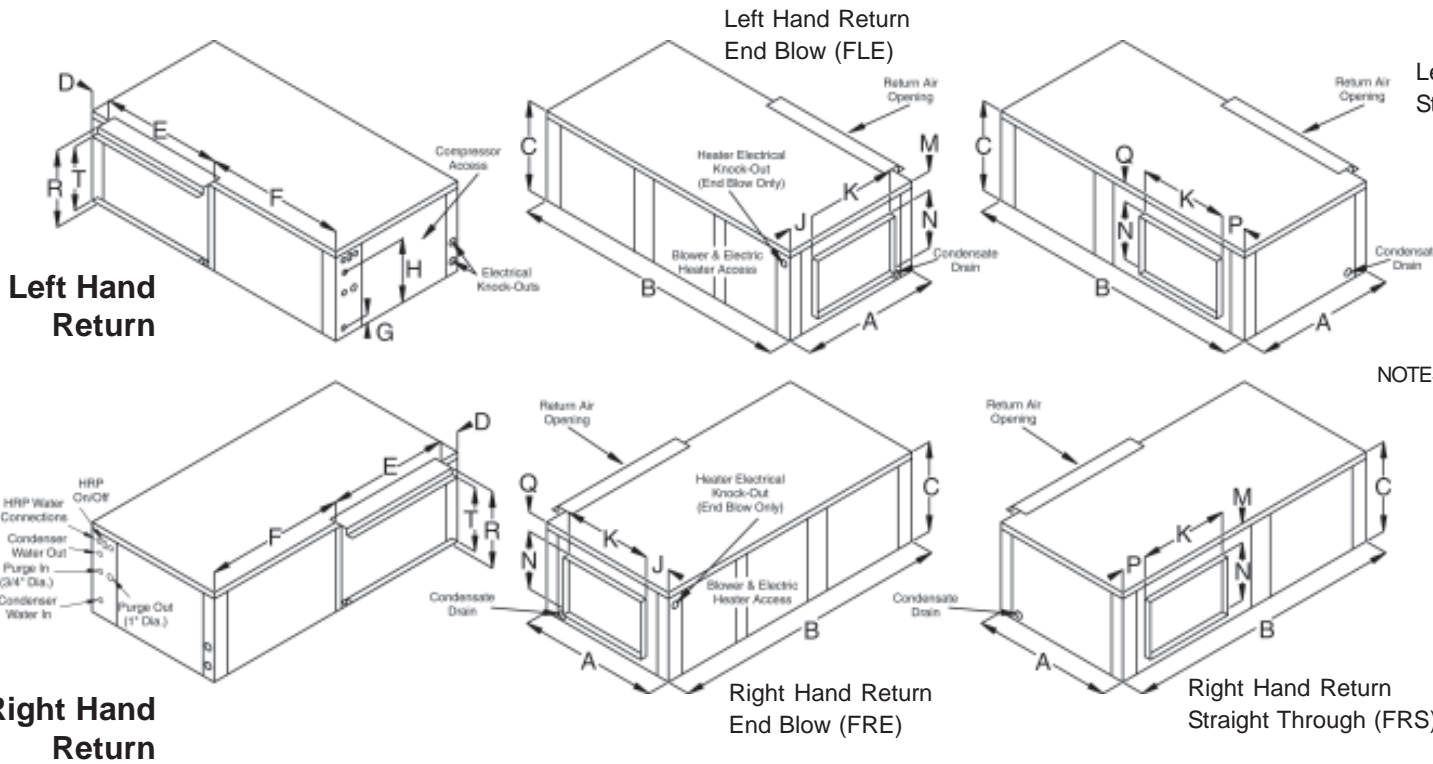

Left Hand Return Straight Through (FLS)

NOTES: All dimensions within +/- 0.125".
 All condensate drain connections are 3/4" FPT.
 All Heat Recovery connections are 1/2" FPT.
 Internal electric heat available on 208-230 volt units only
 Internal Loop Pump available on 208-230 volt units only.
 Internal Heat Recovery Kit available on 208-230 volt units only.
 Units can be field converted between end blow and straight through supply air configurations.
 Specifications subject to change without notice.



FHP Manufacturing Co.
 601 N.W. 65th Court
 Fort Lauderdale, FL 33309
 Phone: (954) 776-5471
 Fax: (800) 776-5529
<http://www.fhp-mfg.com>

GT/GS Series Counterflow Dimensions

MODEL	A	B	C	D	E	F	G	H	J	K	M	N	P	Condenser Water Connections	Recommended Replacement Nominal Filter Size
	Width	Depth	Height	Blower Opening	Blower Opening						R/A Duct Flg Width	R/A Duct Flg Height	Filter Rack Height		
GT010	21.50	21.50	36.25	6.50	9.00	7.50	5.50	5.50	15.00	7.00	17.50	14.00	16.00	3/4" F.P.T.	16 X 20 X 1
GT/GS018	21.50	21.50	40.25	9.25	9.63	5.00	5.13	5.50	15.00	10.13	17.50	18.00	20.00	3/4" F.P.T.	20 X 20 X 1
GT/GS024	21.50	21.50	40.25	9.25	9.63	5.00	5.13	6.50	15.50	10.13	17.50	16.00	18.00	3/4" F.P.T.	20 X 20 X 1
GT/GS030, 036	21.50	26.00	47.25	9.25	10.25	8.38	5.00	7.00	17.00	9.75	22.00	22.00	24.00	3/4" F.P.T.	24 X 24 X 1
GT/GS042	24.00	32.75	47.25	9.25	10.25	11.63	4.50	7.50	18.50	9.25	28.00	22.00	24.00	1" F.P.T.	24 X 30 X 1
GT/GS048	24.00	32.75	47.25	10.75	11.50	11.13	6.88	7.50	18.50	8.75	28.00	22.00	24.00	1" F.P.T.	24 X 30 X 1
GT/GS054	26.00	33.25	51.25	10.75	11.50	11.13	6.88	7.00	20.25	9.50	28.00	22.00	24.00	1" F.P.T.	24 X 30 X 1
GT/GS062	26.00	33.25	51.25	12.00	12.50	10.63	5.00	7.00	20.25	10.50	28.00	22.00	24.00	1" F.P.T.	24 X 30 X 1
G/GST070	26.00	33.25	58.25	12.00	12.50	10.63	5.00	7.00	20.25	10.50	28.00	30.00	32.00	1" F.P.T.	16 X 30 X 1 (2)

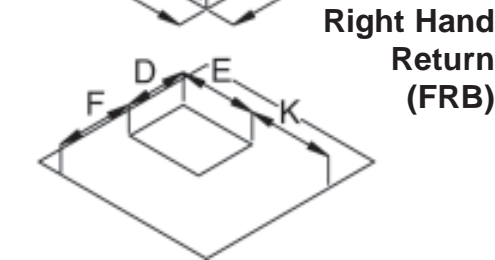
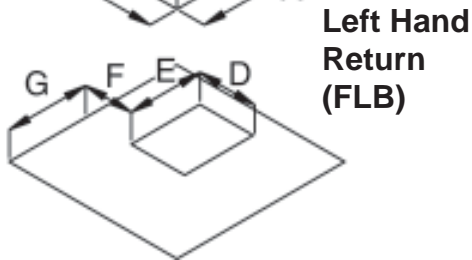
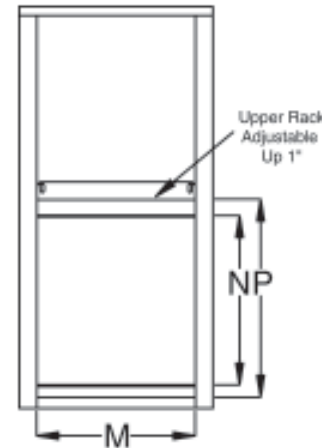
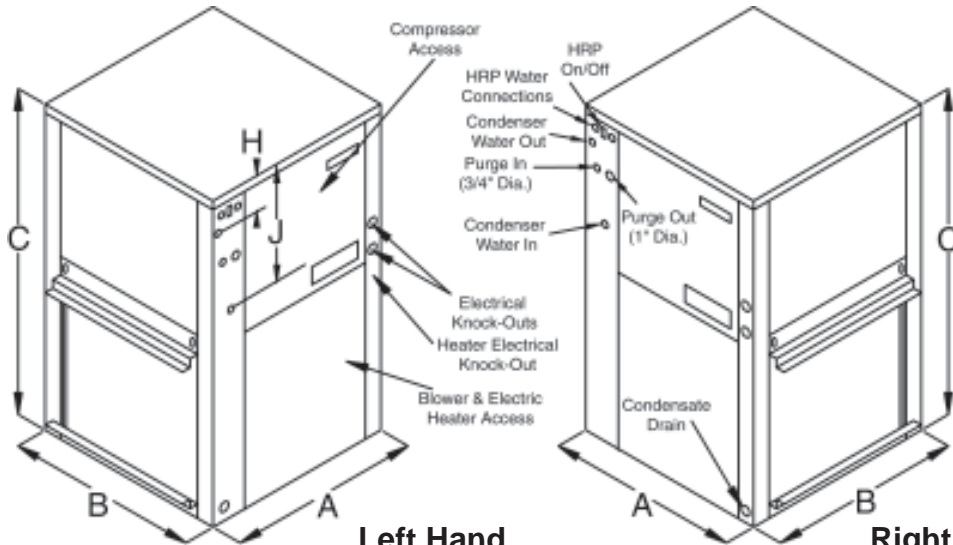

NOTES: All dimensions within +/- 0.125".
 All condensate drain connections are 3/4" FPT.
 All Heat Recovery Kit connections are 1/2" FPT.
 Internal electric heat available on 208-230/1/60 bottom discharge units only
 Internal Loop Pump available on 208-230 volt units only.
 Internal Heat Recovery Kit available on 208-230 volt units only.
 Specifications subject to change without notice.



PACKAGED UNITS SPECIFICATION DATA SHEET

FHP MANUFACTURING HIGH-EFFICIENCY WATER SOURCE HEAT PUMPS

GT010

GEO-THERMAL

ELECTRICAL SPECIFICATIONS

Electrical Characteristics	Elect. Symbol	Compressor		Blower		Loop Pump		Min. Circuit Amps	Max. Fuse/Breaker
		RLA	LRA	FLA	HP	FLA	HP		
115-1-60	-0	8.3	44.0	2.2	1/10	-	-	12.6	20
208/230-1-60	-1	4.5	35.0	1.0	1/10	-	-	8.4	15
265-1-60	-2	3.3	23.0	0.9	1/10	-	-	5.0	15

MECHANICAL SPECIFICATIONS

Refrigerant: R-22			
Air Coil			
Square Feet	Rows Deep	Tube O.D.	Fins/Inch
1.38	3	3/8	14
Water Coil			
Type	Work Press		
Coaxial	450 psig		
Blower Size	Compr Type		
4x7 DD	Rotary		
Net Weight	Ship Weight		
152 lbs	168 lbs		

BLOWER PERFORMANCE

Available External Static Pressure (Inches of Water, Gauge. Wet Coil and Filter Included)												
Blower Speed	0.10	0.20	0.30	0.40	0.50	0.60	0.70	0.80	0.90	1.00	1.10	1.20
High	-	-	-	-	405	385	340	280	-	-	-	-
Medium	-	-	-	405	385	345	290	-	-	-	-	-
Low	415	410	400	380	345	300	-	-	-	-	-	-



ISO 13256-1 CERTIFIED PERFORMANCE DATA Rated at 350 CFM and 3.0 GPM

Water Loop				Ground Water				Ground Loop			
Cooling		Heating		Cooling		Heating		Cooling		Heating	
Capacity	EER	Capacity	COP	Capacity	EER	Capacity	COP	Capacity	EER	Capacity	COP
10,500	14.0	13,000	4.7	12,000	21.2	10,500	4.1	11,000	16.1	8,300	3.4

FLUID PRESSURE DROP

Fluid Flow (GPM)	Pressure Drop	
	(FOH)	(PSIG)
1.5	2.33	1.01
2	3.90	1.69
2.5	5.83	2.53
3	8.10	3.51
4	13.59	5.89

CAPACITY DATA All performance at 350 CFM and 3.0 GPM

COOLING

EFT Range (Standard)
45°F to 110°F

Entering Fluid Temp. (°F)	Entering Air Temp. (°F)	Total Capacity (MBtuH)	Sensible Capacity (MBtuH)	Sensible to Total Ratio	Power Input (kW)	Heat of Reject (MBtuH)	EER
50°	70°db 61°wb	10.53	6.85	0.65	0.55	12.41	19.1
60°		10.07	6.60	0.66	0.62	12.18	16.3
70°		9.61	6.37	0.66	0.68	11.94	14.0
85°		8.91	6.07	0.68	0.78	11.59	11.4
100°		8.22	5.79	0.70	0.88	11.24	9.3
50°	75°db 63°wb	11.29	8.20	0.73	0.55	13.18	20.4
60°		10.79	7.90	0.73	0.62	12.91	17.4
70°		10.30	7.64	0.74	0.69	12.65	15.0
85°		9.56	7.27	0.76	0.79	12.25	12.1
100°		8.82	6.95	0.79	0.89	11.85	9.9
50°	80°db 67°wb	12.40	9.06	0.73	0.56	14.30	22.2
60°		11.86	8.74	0.74	0.63	13.99	19.0
70°		11.31	8.44	0.75	0.69	13.68	16.3
85°		10.50	8.04	0.77	0.79	13.21	13.2
100°		9.69	7.68	0.79	0.90	12.75	10.8
50°	85°db 71°wb	13.51	9.93	0.74	0.56	15.42	24.1
60°		12.92	9.57	0.74	0.63	15.07	20.5
70°		12.33	9.25	0.75	0.70	14.71	17.7
85°		11.44	8.81	0.77	0.80	14.17	14.3
100°		10.56	8.42	0.80	0.90	13.64	11.7

HEATING

EFT Range (Standard)
25°F to 80°F

Entering Fluid Temp. (°F)	Entering Air Temp. (°F)	Total Capacity (MBtuH)	Power Input (kW)	Heat of Abs. (MBtuH)	COP
50°	60°	11.37	0.80	8.64	4.2
60°		12.69	0.83	9.87	4.5
70°		14.01	0.85	11.10	4.8
80°		15.32	0.88	12.32	5.1
50°		70°	10.76	0.81	7.98
60°	12.00		0.84	9.13	4.2
70°	13.25		0.87	10.28	4.5
80°	14.49		0.89	11.44	4.8
50°	80°		10.03	0.83	7.19
60°		11.19	0.86	8.26	3.8
70°		12.35	0.89	9.33	4.1
80°		13.51	0.91	10.39	4.3

LOW TEMP HEATING

Antifreeze Required

25°	60°	7.92	0.74	5.41	3.2
30°		8.57	0.75	6.01	3.4
40°		9.86	0.77	7.21	3.7
25°	70°	7.50	0.75	4.94	2.9
30°		8.11	0.76	5.51	3.1
40°		9.33	0.79	6.64	3.5
25°	80°	7.00	0.76	4.39	2.7
30°		7.57	0.78	4.91	2.9
40°		8.70	0.81	5.95	3.2

Units are complete packages containing a compressor, reversing valve, expansion valve metering device, and heat exchangers. Also included are safety controls: Overload protection for motors, high and low refrigerant pressure switches and a solid state lock-out circuit. Optional UL approved internal electric heater, factory installed with primary thermal overload protection and magnetic contactors (208/230-1-60 only). Optional UL approved internal Heat Recovery Package and/or Ground Loop Pump with purge connections available.

Performance based on ARI/ISO rated air flow, fluid flow and voltage. For conditions other than rated, consult the FHP EAD selection software. Due to variations in installation actual performance may vary marginally from tabulated values.

As a result of continuing research and development, specifications are subject to change without notice.
GT010ip6 mod2 Rev. 10-06

FHP MANUFACTURING COMPANY

601 N.W. 65th Court - Fort Lauderdale, FL 33309

Phone: (954) 776-5471 - Fax: (800) 776-5529

<http://www.fhp-mfg.com>



PACKAGED UNITS SPECIFICATION DATA SHEET

FHP MANUFACTURING HIGH-EFFICIENCY WATER SOURCE HEAT PUMPS

GT018

GEO-THERMAL

ELECTRICAL SPECIFICATIONS

Electrical Characteristics	Elect. Symbol	Compressor		Blower		Loop Pump		Min. Circuit Amps	Max. Fuse/Breaker
		RLA	LRA	FLA	HP	FLA	HP		
208/230-1-60	-1	5.9	29.0	1.8	1/4	-	-	11.0	15
265-1-60	-2	5.5	27.0	1.6	1/4	-	-	8.5	15

MECHANICAL SPECIFICATIONS

Refrigerant: R-22			
Air Coil			
Square Feet	Rows Deep	Tube O.D.	Fins/Inch
2.3	3	3/8	14
Water Coil			
Type	Work Press		
Coaxial	450 psig		
Blower Size	Compr Type		
9x7 DD	Rotary		
Net Weight	Ship Weight		
170 lbs	181 lbs		

BLOWER PERFORMANCE

Available External Static Pressure (Inches of Water, Gauge. Wet Coil and Filter Included)												
Blower Speed	0.10	0.20	0.30	0.40	0.50	0.60	0.70	0.80	0.90	1.00	1.10	1.20
High	-	-	-	750	720	640	510	460	-	-	-	-
Medium	-	-	750	720	650	530	480	-	-	-	-	-
Low	760	730	670	555	490	420	-	-	-	-	-	-



FLUID PRESSURE DROP

Fluid Flow (GPM)	Pressure Drop	
	(FOH)	(PSIG)
2	1.35	0.58
3	2.80	1.21
4	4.70	2.03
5	7.02	3.04
6	9.75	4.22

ISO 13256-1 CERTIFIED PERFORMANCE DATA Rated at 550 CFM and 4.0 GPM

Water Loop				Ground Water				Ground Loop			
Cooling		Heating		Cooling		Heating		Cooling		Heating	
Capacity	EER	Capacity	COP	Capacity	EER	Capacity	COP	Capacity	EER	Capacity	COP
15,500	16.0	16,300	5.0	17,200	24.0	13,200	4.4	16,000	18.3	10,600	3.7

CAPACITY DATA All performance at 550 CFM and 4.0 GPM

COOLING

EFT Range (Standard)
45°F to 110°F

Entering Fluid Temp. (°F)	Entering Air Temp. (°F)	Total Capacity (MBtuH)	Sensible Capacity (MBtuH)	Sensible to Total Ratio	Power Input (kW)	Heat of Reject (MBtuH)	EER
50°	70°db 61°wb	14.85	9.62	0.65	0.74	17.38	20.1
60°		14.33	9.35	0.65	0.83	17.16	17.2
70°		13.80	9.12	0.66	0.92	16.95	15.0
85°		13.02	8.83	0.68	1.06	16.63	12.3
100°		12.23	8.59	0.70	1.20	16.32	10.2
50°	75°db 63°wb	15.93	11.54	0.72	0.74	18.47	21.4
60°		15.37	11.23	0.73	0.84	18.22	18.4
70°		14.81	10.95	0.74	0.93	17.97	16.0
85°		13.97	10.61	0.76	1.06	17.60	13.1
100°		13.13	10.32	0.79	1.20	17.23	10.9
50°	80°db 67°wb	17.50	12.76	0.73	0.75	20.06	23.4
60°		16.89	12.42	0.74	0.84	19.76	20.1
70°		16.28	12.12	0.74	0.93	19.46	17.4
85°		15.35	11.73	0.76	1.07	19.01	14.3
100°		14.43	11.42	0.79	1.21	18.57	11.9
50°	85°db 71°wb	19.08	14.00	0.73	0.75	21.65	25.3
60°		18.41	13.62	0.74	0.85	21.30	21.7
70°		17.74	13.29	0.75	0.94	20.95	18.9
85°		16.74	12.87	0.77	1.08	20.43	15.5
100°		15.74	12.53	0.80	1.22	19.90	12.9

HEATING

EFT Range (Standard)
25°F to 80°F

Entering Fluid Temp. (°F)	Entering Air Temp. (°F)	Total Capacity (MBtuH)	Power Input (kW)	Heat of Abs. (MBtuH)	COP
50°	60°	14.49	1.00	11.09	4.3
60°		16.08	1.03	12.58	4.6
70°		17.68	1.06	14.06	4.9
80°		19.27	1.09	15.55	5.2
50°		70°	13.71	1.01	10.26
60°	15.22		1.04	11.65	4.3
70°	16.72		1.08	13.05	4.6
80°	18.23		1.11	14.45	4.8
50°	80°		12.80	1.03	9.28
60°		14.20	1.07	10.57	3.9
70°		15.60	1.10	11.86	4.2
80°		17.01	1.13	13.15	4.4

LOW TEMP HEATING

Antifreeze Required

25°	60°	10.30	0.92	7.17	3.3
30°		11.08	0.93	7.90	3.5
40°		12.64	0.96	9.35	3.8
25°	70°	9.75	0.93	6.57	3.1
30°		10.49	0.95	7.26	3.2
40°		11.97	0.98	8.62	3.6
25°	80°	9.11	0.95	5.87	2.8
30°		9.80	0.97	6.50	3.0
40°		11.18	1.00	7.76	3.3

Units are complete packages containing a compressor, reversing valve, expansion valve metering device, and heat exchangers. Also included are safety controls: Overload protection for motors, high and low refrigerant pressure switches and a solid state lock-out circuit. Optional UL approved internal electric heater, factory installed with primary thermal overload protection and magnetic contactors (208/230-1-60 only). Optional UL approved internal Heat Recovery Package and/or Ground Loop Pump with purge connections available.

Performance based on ARI/ISO rated air flow, fluid flow and voltage. For conditions other than rated, consult the FHP EAD selection software. Due to variations in installation actual performance may vary marginally from tabulated values.

As a result of continuing research and development, specifications are subject to change without notice.
GT018ip6 mod2 Rev: 10-06

FHP MANUFACTURING COMPANY

601 N.W. 65th Court - Fort Lauderdale, FL 33309

Phone: (954) 776-5471 - Fax: (800) 776-5529

<http://www.fhp-mfg.com>



PACKAGED UNITS SPECIFICATION DATA SHEET

FHP MANUFACTURING HIGH-EFFICIENCY WATER SOURCE HEAT PUMPS

GT024

GEO-THERMAL

ELECTRICAL SPECIFICATIONS

Electrical Characteristics	Elect. Symbol	Compressor		Blower		Loop Pump		Min. Circuit Amps	Max. Fuse/Breaker
		RLA	LRA	FLA	HP	FLA	HP		
208/230-1-60	-1	10.3	56.0	1.8	1/4	-	-	16.5	20
265-1-60	-2	8.7	47.0	1.6	1/4	-	-	12.5	15
208/230-3-60	-3	7.1	45.0	1.8	1/4	-	-	10.7	15
460-3-60	-4	3.5	22.4	0.9	1/4	-	-	5.3	15

MECHANICAL SPECIFICATIONS

Refrigerant: R-22			
Air Coil			
Square Feet	Rows Deep	Tube O.D.	Fins/Inch
2.12	3	3/8	14
Water Coil			
Type	Work Press		
Coaxial	450 psig		
Blower Size	Compr Type		
9x7 DD	Scroll		
Net Weight	Ship Weight		
174 lbs	185 lbs		

BLOWER PERFORMANCE

Available External Static Pressure (Inches of Water, Gauge. Wet Coil and Filter Included)												
Blower Speed	0.10	0.20	0.30	0.40	0.50	0.60	0.70	0.80	0.90	1.00	1.10	1.20
High	900	850	800	760	710	690	680	670	-	-	-	-
Medium	750	720	690	670	-	-	-	-	-	-	-	-
Low	670	-	-	-	-	-	-	-	-	-	-	-



ISO 13256-1 CERTIFIED PERFORMANCE DATA Rated at 800 CFM and 5.0 GPM

Water Loop				Ground Water				Ground Loop			
Cooling		Heating		Cooling		Heating		Cooling		Heating	
Capacity	EER	Capacity	COP	Capacity	EER	Capacity	COP	Capacity	EER	Capacity	COP
23,500	14.2	28,500	4.6	26,400	21.0	23,200	4.1	24,500	16.2	18,200	3.5

FLUID PRESSURE DROP

Fluid Flow (GPM)	Pressure Drop	
	(FOH)	(PSIG)
3	1.26	0.55
5	3.17	1.37
6	4.40	1.90
8	7.38	3.20
10	11.04	4.78

CAPACITY DATA All performance at 800 CFM and 5.0 GPM

COOLING EFT Range (Standard) 45°F to 110°F							
Entering Fluid Temp. (°F)	Entering Air Temp. (°F)	Total Capacity (MBtuH)	Sensible Capacity (MBtuH)	Sensible to Total Ratio	Power Input (kW)	Heat of Reject (MBtuH)	EER
50°	70°db 61°wb	23.25	15.18	0.65	1.19	27.32	19.5
60°		22.36	14.72	0.66	1.34	26.93	16.7
70°		21.48	14.32	0.67	1.48	26.53	14.5
85°		20.15	13.78	0.68	1.70	25.94	11.9
100°		18.82	13.32	0.71	1.91	25.35	9.8
50°	75°db 63°wb	24.91	18.15	0.73	1.20	29.00	20.8
60°		23.96	17.60	0.73	1.34	28.55	17.8
70°		23.01	17.11	0.74	1.49	28.10	15.5
85°		21.59	16.48	0.76	1.71	27.42	12.7
100°		20.16	15.93	0.79	1.93	26.74	10.7
50°	80°db 67°wb	27.34	20.03	0.73	1.21	31.46	22.6
60°		26.30	19.43	0.74	1.35	30.92	19.4
70°		25.26	18.89	0.75	1.50	30.38	16.8
85°		23.70	18.19	0.77	1.72	29.57	13.8
100°		22.14	17.59	0.79	1.94	28.76	11.4
50°	85°db 71°wb	29.77	21.93	0.74	1.22	33.92	24.5
60°		28.64	21.28	0.74	1.36	33.29	21.0
70°		27.50	20.69	0.75	1.51	32.67	18.2
85°		25.81	19.93	0.77	1.73	31.73	14.9
100°		24.11	19.27	0.80	1.96	30.78	12.3

HEATING EFT Range (Standard) 25°F to 80°F

Entering Fluid Temp. (°F)	Entering Air Temp. (°F)	Total Capacity (MBtuH)	Power Input (kW)	Heat of Abs. (MBtuH)	COP
50°	60°	24.81	1.72	18.92	4.2
60°		27.69	1.80	21.53	4.5
70°		30.58	1.88	24.14	4.8
80°		33.46	1.96	26.76	5.0
50°		70°	23.45	1.76	17.46
60°	26.18		1.84	19.91	4.2
70°	28.90		1.92	22.36	4.4
80°	31.63		2.00	24.80	4.6
50°	80°		21.86	1.80	15.74
60°		24.40	1.88	17.99	3.8
70°		26.94	1.96	20.25	4.0
80°		29.48	2.04	22.50	4.2

LOW TEMP HEATING

Antifreeze Required

25°	60°	17.25	1.53	12.04	3.3
30°		18.66	1.57	13.32	3.5
40°		21.49	1.65	15.88	3.8
25°	70°	16.31	1.55	11.01	3.1
30°		17.65	1.59	12.21	3.2
40°		20.32	1.68	14.60	3.6
25°	80°	15.21	1.59	9.80	2.8
30°		16.46	1.63	10.90	3.0
40°		18.95	1.71	13.10	3.2

Units are complete packages containing a compressor, reversing valve, expansion valve metering device, and heat exchangers. Also included are safety controls: Overload protection for motors, high and low refrigerant pressure switches and a solid state lock-out circuit. Optional UL approved internal electric heater, factory installed with primary thermal overload protection and magnetic contactors (208/230-1-60 only). Optional UL approved internal Heat Recovery Package and/or Ground Loop Pump with purge connections available.

Performance based on ARI/ISO rated air flow, fluid flow and voltage. For conditions other than rated, consult the FHP EAD selection software. Due to variations in installation actual performance may vary marginally from tabulated values.

As a result of continuing research and development, specifications are subject to change without notice.
GT024ip6 mod2 Rev. 10-06

FHP MANUFACTURING COMPANY

601 N.W. 65th Court - Fort Lauderdale, FL 33309

Phone: (954) 776-5471 - Fax: (800) 776-5529

<http://www.fhp-mfg.com>



PACKAGED UNITS SPECIFICATION DATA SHEET

FHP MANUFACTURING HIGH-EFFICIENCY WATER SOURCE HEAT PUMPS

GT030

GEO-THERMAL

ELECTRICAL SPECIFICATIONS

Electrical Characteristics	Elect. Symbol	Compressor		Blower		Loop Pump		Min. Circuit Amps	Max. Fuse/Breaker
		RLA	LRA	FLA	HP	FLA	HP		
208/230-1-60	-1	10.3	56.0	1.80	1/4	-	-	16.5	20
265-1-60	-2	8.7	47.0	1.60	1/4	-	-	12.5	15
208/230-3-60	-3	7.1	45.0	1.80	1/4	-	-	10.7	15
460-3-60	-4	3.5	22.4	0.90	1/4	-	-	5.3	15

MECHANICAL SPECIFICATIONS

Refrigerant: R-22			
Air Coil			
Square Feet	Rows Deep	Tube O.D.	Fins/Inch
3.50	3	3/8	14
Water Coil			
Type	Work Press		
Coaxial	450 psig		
Blower Size	Compr Type		
9x7 DD	Scroll		
Net Weight	Ship Weight		
231 lbs	251 lbs		

BLOWER PERFORMANCE

Available External Static Pressure (Inches of Water, Gauge. Wet Coil and Filter Included)												
Blower Speed	0.10	0.20	0.30	0.40	0.50	0.60	0.70	0.80	0.90	1.00	1.10	1.20
High	1275	1210	1140	1060	980	900	820	720	-	-	-	-
Medium	1040	1010	970	920	860	790	730	-	-	-	-	-
Low	950	930	900	860	810	750	-	-	-	-	-	-



ISO 13256-1 CERTIFIED PERFORMANCE DATA Rated at 1,000 CFM and 7.5 GPM

Water Loop				Ground Water				Ground Loop			
Cooling		Heating		Cooling		Heating		Cooling		Heating	
Capacity	EER	Capacity	COP	Capacity	EER	Capacity	COP	Capacity	EER	Capacity	COP
28,000	16.0	33,200	5.7	30,000	24.0	26,000	4.7	29,000	18.5	19,000	4.0

FLUID PRESSURE DROP

Fluid Flow (GPM)	Pressure Drop	
	(FOH)	(PSIG)
4	2.07	0.90
6	4.29	1.86
8	7.20	3.12
10	10.76	4.66
12	14.94	6.47

CAPACITY DATA All performance at 1,000 CFM and 7.5 GPM

COOLING EFT Range (Standard) 45°F to 110°F							
Entering Fluid Temp. (°F)	Entering Air Temp. (°F)	Total Capacity (MBtuH)	Sensible Capacity (MBtuH)	Sensible to Total Ratio	Power Input (kW)	Heat of Reject (MBtuH)	EER
50°	70°db	26.12	17.28	0.66	1.13	29.99	23.0
60°		25.55	17.04	0.67	1.32	30.04	19.4
70°		24.97	16.87	0.68	1.50	30.08	16.7
85°		24.11	16.72	0.69	1.77	30.15	13.6
100°		23.25	16.68	0.72	2.04	30.22	11.4
50°	75°db	27.98	20.64	0.74	1.14	31.88	24.5
60°		27.37	20.36	0.74	1.32	31.88	20.7
70°		26.76	20.15	0.75	1.51	31.89	17.8
85°		25.83	19.98	0.77	1.78	31.91	14.5
100°		24.91	19.94	0.80	2.05	31.92	12.1
50°	80°db	30.71	22.78	0.74	1.15	34.63	26.7
60°		30.04	22.47	0.75	1.33	34.59	22.5
70°		29.36	22.25	0.76	1.52	34.54	19.4
85°		28.35	22.05	0.78	1.79	34.47	15.8
100°		27.34	22.01	0.80	2.07	34.40	13.2
50°	85°db	33.44	24.95	0.75	1.16	37.39	28.9
60°		32.70	24.61	0.75	1.34	37.29	24.3
70°		31.97	24.36	0.76	1.53	37.19	20.9
85°		30.87	24.14	0.78	1.81	37.04	17.1
100°		29.77	24.10	0.81	2.09	36.89	14.3

HEATING EFT Range (Standard) 25°F to 80°F

Entering Fluid Temp. (°F)	Entering Air Temp. (°F)	Total Capacity (MBtuH)	Power Input (kW)	Heat of Abs. (MBtuH)	COP
50°	60°	27.72	1.62	22.20	5.0
60°		31.73	1.70	25.91	5.5
70°		35.74	1.79	29.63	5.9
80°		39.76	1.88	33.35	6.2
50°		70°	26.20	1.65	20.58
60°	29.99		1.73	24.07	5.1
70°	33.79		1.82	27.57	5.4
80°	37.58		1.91	31.06	5.8
50°	80°		24.43	1.68	18.68
60°		27.96	1.77	21.91	4.6
70°		31.49	1.86	25.13	5.0
80°		35.02	1.95	28.36	5.3

LOW TEMP HEATING

Antifreeze Required

25°	60°	17.34	1.40	12.55	3.6
30°		19.30	1.45	14.37	3.9
40°		23.24	1.53	18.01	4.4
25°	70°	16.40	1.43	11.53	3.4
30°		18.26	1.47	13.23	3.6
40°		21.97	1.56	16.65	4.1
25°	80°	15.29	1.46	10.32	3.1
30°		17.02	1.50	11.89	3.3
40°		20.49	1.59	15.05	3.8

Units are complete packages containing a compressor, reversing valve, expansion valve metering device, and heat exchangers. Also included are safety controls: Overload protection for motors, high and low refrigerant pressure switches and a solid state lock-out circuit. Optional UL approved internal electric heater, factory installed with primary thermal overload protection and magnetic contactors (208/230-1-60 only). Optional UL approved internal Heat Recovery Package and/or Ground Loop Pump with purge connections available.

Performance based on ARI/ISO rated air flow, fluid flow and voltage. For conditions other than rated, consult the FHP EAD selection software. Due to variations in installation actual performance may vary marginally from tabulated values.

As a result of continuing research and development, specifications are subject to change without notice.
GT030ip6mod2 Rev: 10-06

FHP MANUFACTURING COMPANY

601 N.W. 65th Court - Fort Lauderdale, FL 33309

Phone: (954) 776-5471 - Fax: (800) 776-5529

<http://www.fhp-mfg.com>



PACKAGED UNITS SPECIFICATION DATA SHEET

FHP MANUFACTURING HIGH-EFFICIENCY WATER SOURCE HEAT PUMPS

GT036

GEO-THERMAL

ELECTRICAL SPECIFICATIONS

Electrical Characteristics	Elect. Symbol	Compressor		Blower		Loop Pump		Min. Circuit Amps	Max. Fuse/Breaker
		RLA	LRA	FLA	HP	FLA	HP		
208/230-1-60	-1	13.5	72.5	3.90	1/2	-	-	22.5	30
265-1-60	-2	11.5	61.0	2.30	1/2	-	-	16.7	25
208/230-3-60	-3	9.0	63.0	3.90	1/2	-	-	15.2	20
460-3-60	-4	4.5	31.0	2.00	1/2	-	-	7.6	15

MECHANICAL SPECIFICATIONS

Refrigerant: R-22			
Air Coil			
Square Feet	Rows Deep	Tube O.D.	Fins/Inch
3.50	3	3/8	14
Water Coil			
Type	Work Press		
Coaxial	450 psig		
Blower Size	Compr Type		
9x7 DD	Scroll		
Net Weight	Ship Weight		
243 lbs	263 lbs		

BLOWER PERFORMANCE

Available External Static Pressure (Inches of Water, Gauge. Wet Coil and Filter Included)												
Blower Speed	0.10	0.20	0.30	0.40	0.50	0.60	0.70	0.80	0.90	1.00	1.10	1.20
High	1500	1440	1370	1290	1210	1120	1020	900	-	-	-	-
Medium	1410	1350	1290	1220	1150	1060	960	-	-	-	-	-
Low	1290	1250	1200	1150	1080	1000	-	-	-	-	-	-



ISO 13256-1 CERTIFIED PERFORMANCE DATA Rated at 1,200 CFM and 9.0 GPM

Water Loop				Ground Water				Ground Loop			
Cooling		Heating		Cooling		Heating		Cooling		Heating	
Capacity	EER	Capacity	COP	Capacity	EER	Capacity	COP	Capacity	EER	Capacity	COP
34,000	14.6	40,500	5.1	37,800	21.5	32,400	4.4	35,000	17.0	24,500	3.5

FLUID PRESSURE DROP

Fluid Flow (GPM)	Pressure Drop	
	(FOH)	(PSIG)
5	3.05	1.32
7	5.60	2.42
9	8.80	3.81
11	12.63	5.47
13	17.06	7.38

CAPACITY DATA All performance at 1,200 CFM and 9.0 GPM

COOLING EFT Range (Standard) 45°F to 110°F							
Entering Fluid Temp. (°F)	Entering Air Temp. (°F)	Total Capacity (MBtuH)	Sensible Capacity (MBtuH)	Sensible to Total Ratio	Power Input (kW)	Heat of Reject (MBtuH)	EER
50°	70°db	33.13	21.89	0.66	1.63	38.68	20.4
60°		31.95	21.29	0.67	1.83	38.19	17.5
70°		30.77	20.76	0.67	2.03	37.70	15.1
85°		29.00	20.08	0.69	2.33	36.97	12.4
100°		27.23	19.52	0.72	2.64	36.24	10.3
50°	75°db	35.50	26.17	0.74	1.64	41.08	21.7
60°		34.23	25.45	0.74	1.84	40.51	18.6
70°		32.97	24.82	0.75	2.04	39.94	16.1
85°		31.08	24.01	0.77	2.35	39.09	13.2
100°		29.19	23.34	0.80	2.65	38.24	11.0
50°	80°db	38.96	28.89	0.74	1.65	44.59	23.6
60°		37.58	28.10	0.75	1.85	43.90	20.3
70°		36.19	27.40	0.76	2.06	43.22	17.6
85°		34.12	26.51	0.78	2.37	42.19	14.4
100°		32.04	25.77	0.80	2.67	41.17	12.0
50°	85°db	42.42	31.64	0.75	1.66	48.09	25.5
60°		40.92	30.77	0.75	1.87	47.29	21.9
70°		39.41	30.01	0.76	2.07	46.49	19.0
85°		37.15	29.04	0.78	2.38	45.29	15.6
100°		34.90	28.23	0.81	2.70	44.09	12.9

HEATING EFT Range (Standard) 25°F to 80°F

Entering Fluid Temp. (°F)	Entering Air Temp. (°F)	Total Capacity (MBtuH)	Power Input (kW)	Heat of Abs. (MBtuH)	COP
50°	60°	34.59	2.24	26.95	4.5
60°		39.10	2.31	31.20	5.0
70°		43.60	2.39	35.45	5.3
80°		48.10	2.46	39.69	5.7
50°		70°	32.71	2.28	24.93
60°	36.96		2.36	28.92	4.6
70°	41.22		2.43	32.92	5.0
80°	45.47		2.51	36.91	5.3
50°	80°		30.49	2.33	22.55
60°		34.46	2.41	26.24	4.2
70°		38.42	2.49	29.94	4.5
80°		42.38	2.56	33.63	4.8

LOW TEMP HEATING

Antifreeze Required

25°	60°	22.88	2.05	15.88	3.3
30°		25.08	2.09	17.96	3.5
40°		29.50	2.16	22.12	4.0
25°	70°	21.64	2.09	14.52	3.0
30°		23.72	2.12	16.47	3.3
40°		27.89	2.20	20.38	3.7
25°	80°	20.18	2.13	12.91	2.8
30°		22.13	2.17	14.72	3.0
40°		26.01	2.25	18.33	3.4

Units are complete packages containing a compressor, reversing valve, expansion valve metering device, and heat exchangers. Also included are safety controls: Overload protection for motors, high and low refrigerant pressure switches and a solid state lock-out circuit. Optional UL approved internal electric heater, factory installed with primary thermal overload protection and magnetic contactors (208/230-1-60 only). Optional UL approved internal Heat Recovery Package and/or Ground Loop Pump with purge connections available.

Performance based on ARI/ISO rated air flow, fluid flow and voltage. For conditions other than rated, consult the FHP EAD selection software. Due to variations in installation actual performance may vary marginally from tabulated values.

As a result of continuing research and development, specifications are subject to change without notice.
GT036ip6 mod2 Rev. 10-06

FHP MANUFACTURING COMPANY

601 N.W. 65th Court - Fort Lauderdale, FL 33309

Phone: (954) 776-5471 - Fax: (800) 776-5529

<http://www.fhp-mfg.com>



PACKAGED UNITS SPECIFICATION DATA SHEET

FHP MANUFACTURING HIGH-EFFICIENCY WATER SOURCE HEAT PUMPS

GT042

GEO-THERMAL

ELECTRICAL SPECIFICATIONS

Electrical Characteristics	Elect. Symbol	Compressor		Blower		Loop Pump		Min. Circuit Amps	Max. Fuse/Breaker
		RLA	LRA	FLA	HP	FLA	HP		
208/230-1-60	-1	16.0	88.0	3.9	1/2	-	-	25.7	35
265-1-60	-2	12.8	75.0	2.3	1/2	-	-	18.3	30
208/230-3-60	-3	10.3	77.0	3.9	1/2	-	-	16.8	25
460-3-60	-4	5.1	39.0	2.0	1/2	-	-	8.4	15

MECHANICAL SPECIFICATIONS

Refrigerant: R-22			
Air Coil			
Square Feet	Rows Deep	Tube O.D.	Fins/Inch
4.50	3	3/8	14
Water Coil			
Type	Work Press		
Coaxial	450 psig		
Blower Size	Compr Type		
9x7 DD	Scroll		
Net Weight	Ship Weight		
260 lbs	280 lbs		

BLOWER PERFORMANCE

Available External Static Pressure (Inches of Water, Gauge. Wet Coil and Filter Included)												
Blower Speed	0.10	0.20	0.30	0.40	0.50	0.60	0.70	0.80	0.90	1.00	1.10	1.20
High	-	1570	1500	1420	1330	1260	1190	1100	-	-	-	-
Medium	1560	1520	1450	1380	1290	1140	1000	-	-	-	-	-
Low	1380	1290	1200	1090	980	-	-	-	-	-	-	-



ISO 13256-1 CERTIFIED PERFORMANCE DATA Rated at 1,400 CFM and 9.0 GPM

Water Loop				Ground Water				Ground Loop			
Cooling		Heating		Cooling		Heating		Cooling		Heating	
Capacity	EER	Capacity	COP	Capacity	EER	Capacity	COP	Capacity	EER	Capacity	COP
39,600	14.8	48,500	5.3	44,000	21.2	39,000	4.5	41,000	16.6	30,000	3.7

FLUID PRESSURE DROP

Fluid Flow (GPM)	Pressure Drop	
	(FOH)	(PSIG)
5	1.98	0.86
7	3.63	1.57
9	5.70	2.47
13	11.05	4.78
15	14.30	6.19

CAPACITY DATA All performance at 1,400 CFM and 9.0 GPM

COOLING EFT Range (Standard) 45°F to 110°F							
Entering Fluid Temp. (°F)	Entering Air Temp. (°F)	Total Capacity (MBtuH)	Sensible Capacity (MBtuH)	Sensible to Total Ratio	Power Input (kW)	Heat of Reject (MBtuH)	EER
50°	70°db	38.40	25.31	0.66	2.04	45.35	18.9
60°		37.05	24.62	0.66	2.26	44.75	16.4
70°		35.70	24.02	0.67	2.47	44.15	14.4
85°		33.68	23.26	0.69	2.80	43.24	12.0
100°		31.66	22.63	0.71	3.13	42.34	10.1
50°	75°db	41.16	30.29	0.74	2.05	48.14	20.1
60°		39.71	29.48	0.74	2.27	47.45	17.5
70°		38.27	28.76	0.75	2.49	46.76	15.4
85°		36.10	27.85	0.77	2.82	45.72	12.8
100°		33.94	27.11	0.80	3.15	44.68	10.8
50°	80°db	45.19	33.46	0.74	2.06	52.23	21.9
60°		43.61	32.56	0.75	2.28	51.40	19.1
70°		42.03	31.77	0.76	2.51	50.58	16.8
85°		39.65	30.78	0.78	2.84	49.34	14.0
100°		37.28	29.95	0.80	3.17	48.11	11.8
50°	85°db	49.22	36.66	0.74	2.08	56.32	23.7
60°		47.50	35.68	0.75	2.30	55.36	20.6
70°		45.78	34.82	0.76	2.53	54.40	18.1
85°		43.20	33.72	0.78	2.86	52.96	15.1
100°		40.62	32.82	0.81	3.20	51.53	12.7

HEATING EFT Range (Standard) 25°F to 80°F

Entering Fluid Temp. (°F)	Entering Air Temp. (°F)	Total Capacity (MBtuH)	Power Input (kW)	Heat of Abs. (MBtuH)	COP
50°	60°	41.90	2.68	32.75	4.6
60°		47.10	2.77	37.66	5.0
70°		52.30	2.85	42.58	5.4
80°		57.50	2.93	47.49	5.7
50°		70°	39.63	2.73	30.31
60°	44.54		2.81	34.93	4.6
70°	49.45		2.90	39.55	5.0
80°	54.36		2.98	44.17	5.3
50°	80°		36.96	2.79	27.44
60°		41.53	2.87	31.72	4.2
70°		46.10	2.96	36.00	4.6
80°		50.68	3.05	40.27	4.9

LOW TEMP HEATING

Antifreeze Required

25°	60°	28.34	2.47	19.90	3.4
30°		30.89	2.51	22.31	3.6
40°		35.98	2.60	27.12	4.1
25°	70°	26.82	2.52	18.23	3.1
30°		29.22	2.56	20.49	3.3
40°		34.04	2.64	25.01	3.8
25°	80°	25.02	2.57	16.25	2.9
30°		27.27	2.61	18.35	3.1
40°		31.75	2.70	22.53	3.4

Units are complete packages containing a compressor, reversing valve, expansion valve metering device, and heat exchangers. Also included are safety controls: Overload protection for motors, high and low refrigerant pressure switches and a solid state lock-out circuit. Optional UL approved internal electric heater, factory installed with primary thermal overload protection and magnetic contactors (208/230-1-60 only). Optional UL approved internal Heat Recovery Package and/or Ground Loop Pump with purge connections available.

Performance based on ARI/ISO rated air flow, fluid flow and voltage. For conditions other than rated, consult the FHP EAD selection software. Due to variations in installation actual performance may vary marginally from tabulated values.

As a result of continuing research and development, specifications are subject to change without notice.
GT042ip6mod2 Rev: 10-06

FHP MANUFACTURING COMPANY

601 N.W. 65th Court - Fort Lauderdale, FL 33309

Phone: (954) 776-5471 - Fax: (800) 776-5529

<http://www.fhp-mfg.com>



PACKAGED UNITS SPECIFICATION DATA SHEET

FHP MANUFACTURING HIGH-EFFICIENCY WATER SOURCE HEAT PUMPS

GT048

GEO-THERMAL

ELECTRICAL SPECIFICATIONS

Electrical Characteristics	Elect. Symbol	Compressor		Blower		Loop Pump		Min. Circuit Amps	Max. Fuse/Breaker
		RLA	LRA	FLA	HP	FLA	HP		
208/230-1-60	-1	18.3	109.0	3.9	1/2	-	-	28.5	45
208/230-3-60	-3	12.4	88.0	3.9	1/2	-	-	19.4	30
460-3-60	-4	6.4	44.0	2.0	1/2	-	-	10.0	15
575-3-60	-5	4.8	34.0	2.6	3/4	-	-	8.6	15

MECHANICAL SPECIFICATIONS

Refrigerant: R-22			
Air Coil			
Square Feet	Rows Deep	Tube O.D.	Fins/Inch
4.50	3	3/8	14
Water Coil			
Type	Work Press		
Coaxial	450 psig		
Blower Size	Compr Type		
10x8 DD	Scroll		
Net Weight	Ship Weight		
310 lbs	334 lbs		

BLOWER PERFORMANCE

Available External Static Pressure (Inches of Water, Gauge. Wet Coil and Filter Included)												
Blower Speed	0.10	0.20	0.30	0.40	0.50	0.60	0.70	0.80	0.90	1.00	1.10	1.20
High	-	1770	1700	1620	1530	1460	1390	1300	1210	-	-	-
Medium	1760	1720	1650	1580	1490	1340	1200	-	-	-	-	-
Low	1580	1490	1400	1290	1180	-	-	-	-	-	-	-



ISO 13256-1 CERTIFIED PERFORMANCE DATA Rated at 1,600 CFM and 12.0 GPM

Water Loop				Ground Water				Ground Loop			
Cooling		Heating		Cooling		Heating		Cooling		Heating	
Capacity	EER	Capacity	COP	Capacity	EER	Capacity	COP	Capacity	EER	Capacity	COP
47,000	13.8	58,000	5.0	52,000	20.1	47,000	4.2	49,000	15.8	36,500	3.5

FLUID PRESSURE DROP

Fluid Flow (GPM)	Pressure Drop	
	(FOH)	(PSIG)
5	2.11	0.91
7	3.87	1.67
9	6.08	2.63
12	10.20	4.42
16	17.12	7.41

CAPACITY DATA All performance at 1,600 CFM and 12.0 GPM

COOLING							
EFT Range (Standard) 45°F to 110°F							
Entering Fluid Temp. (°F)	Entering Air Temp. (°F)	Total Capacity (MBtuH)	Sensible Capacity (MBtuH)	Sensible to Total Ratio	Power Input (kW)	Heat of Reject (MBtuH)	EER
50°	70°db	45.30	29.83	0.66	2.48	53.78	18.2
60°		43.80	29.08	0.66	2.78	53.29	15.8
70°		42.30	28.44	0.67	3.08	52.80	13.7
85°		40.04	27.64	0.69	3.52	52.07	11.4
100°		37.79	27.00	0.71	3.97	51.33	9.5
50°	75°db	48.56	35.72	0.74	2.50	57.08	19.4
60°		46.95	34.83	0.74	2.80	56.49	16.8
70°		45.34	34.06	0.75	3.09	55.90	14.7
85°		42.93	33.11	0.77	3.54	55.02	12.1
100°		40.52	32.35	0.80	3.99	54.14	10.2
50°	80°db	53.32	39.46	0.74	2.52	61.91	21.2
60°		51.56	38.48	0.75	2.82	61.17	18.3
70°		49.80	37.63	0.76	3.12	60.44	16.0
85°		47.16	36.58	0.78	3.57	59.34	13.2
100°		44.51	35.75	0.80	4.02	58.24	11.1
50°	85°db	58.09	43.25	0.74	2.53	66.74	22.9
60°		56.17	42.17	0.75	2.84	65.86	19.8
70°		54.26	41.25	0.76	3.14	64.98	17.3
85°		51.38	40.10	0.78	3.60	63.66	14.3
100°		48.51	39.18	0.81	4.05	62.33	12.0

HEATING

HEATING					
EFT Range (Standard) 25°F to 80°F					
Entering Fluid Temp. (°F)	Entering Air Temp. (°F)	Total Capacity (MBtuH)	Power Input (kW)	Heat of Abs. (MBtuH)	COP
50°	60°	50.52	3.40	38.91	4.4
60°		56.56	3.50	44.62	4.7
70°		62.59	3.59	50.33	5.1
80°		68.62	3.68	56.05	5.5
50°		70°	47.79	3.46	35.97
60°	53.48		3.56	41.34	4.4
70°	59.18		3.65	46.71	4.7
80°	64.88		3.75	52.08	5.1
50°	80°		44.57	3.54	32.50
60°		49.88	3.63	37.47	4.0
70°		55.18	3.73	42.45	4.3
80°		60.49	3.83	47.42	4.6

LOW TEMP HEATING

LOW TEMP HEATING					
Antifreeze Required					
Entering Fluid Temp. (°F)	Entering Air Temp. (°F)	Total Capacity (MBtuH)	Power Input (kW)	Heat of Abs. (MBtuH)	COP
25°	60°	34.75	3.17	23.94	3.2
30°		37.71	3.21	26.74	3.4
40°		43.62	3.31	32.33	3.9
25°	70°	32.88	3.22	21.88	3.0
30°		35.68	3.27	24.51	3.2
40°		41.26	3.37	29.77	3.6
25°	80°	30.69	3.29	19.46	2.7
30°		33.29	3.34	21.89	2.9
40°		38.49	3.44	26.76	3.3

Units are complete packages containing a compressor, reversing valve, expansion valve metering device, and heat exchangers. Also included are safety controls: Overload protection for motors, high and low refrigerant pressure switches and a solid state lock-out circuit. Optional UL approved internal electric heater, factory installed with primary thermal overload protection and magnetic contactors (208/230-1-60 only). Optional UL approved internal Heat Recovery Package and/or Ground Loop Pump with purge connections available.

Performance based on ARI/ISO rated air flow, fluid flow and voltage. For conditions other than rated, consult the FHP EAD selection software. Due to variations in installation actual performance may vary marginally from tabulated values.

As a result of continuing research and development, specifications are subject to change without notice.
GT048ip6mod2 Rev: 10-06

FHP MANUFACTURING COMPANY

601 N.W. 65th Court - Fort Lauderdale, FL 33309

Phone: (954) 776-5471 - Fax: (800) 776-5529

<http://www.fhp-mfg.com>



PACKAGED UNITS SPECIFICATION DATA SHEET

FHP MANUFACTURING HIGH-EFFICIENCY WATER SOURCE HEAT PUMPS

GT054

GEO-THERMAL

ELECTRICAL SPECIFICATIONS

Electrical Characteristics	Elect. Symbol	Compressor		Blower		Loop Pump		Min. Circuit Amps	Max. Fuse/Breaker
		RLA	LRA	FLA	HP	FLA	HP		
208/230-1-60	-1	23.7	129.0	5.0	3/4	-	-	36.4	50
208/230-3-60	-3	14.7	99.0	5.0	3/4	-	-	23.4	35
460-3-60	-4	7.4	49.5	2.5	3/4	-	-	11.8	15
575-3-60	-5	5.6	40.0	2.6	3/4	-	-	9.6	15

MECHANICAL SPECIFICATIONS

Refrigerant: R-22			
Air Coil			
Square Feet	Rows Deep	Tube O.D.	Fins/Inch
4.50	3	3/8	14
Water Coil			
Type	Work Press		
Coaxial	450 psig		
Blower Size	Compr Type		
10x8 DD	Scroll		
Net Weight	Ship Weight		
360 lbs	385 lbs		

BLOWER PERFORMANCE

Available External Static Pressure (Inches of Water, Gauge. Wet Coil and Filter Included)												
Blower Speed	0.10	0.20	0.30	0.40	0.50	0.60	0.70	0.80	0.90	1.00	1.10	1.20
High	1990	1960	1900	1820	1780	1750	1700	1660	1600	1550	-	-
Medium	1940	1910	1850	1770	1740	1710	1660	1620	-	-	-	-
Low	1900	1870	1810	1710	1685	1660	-	-	-	-	-	-



ISO 13256-1 CERTIFIED PERFORMANCE DATA Rated at 1,800 CFM and 14.0 GPM

Water Loop				Ground Water				Ground Loop			
Cooling		Heating		Cooling		Heating		Cooling		Heating	
Capacity	EER	Capacity	COP	Capacity	EER	Capacity	COP	Capacity	EER	Capacity	COP
51,000	13.3	62,000	4.4	57,000	18.8	52,000	4	52,000	14.6	41,000	3.4

FLUID PRESSURE DROP

Fluid Flow (GPM)	Pressure Drop	
	(FOH)	(PSIG)
6	2.05	0.89
10	5.13	2.22
12	7.12	3.08
14	9.40	4.07
18	14.78	6.40

CAPACITY DATA All performance at 1,800 CFM and 14.0 GPM

COOLING EFT Range (Standard) 45°F to 110°F							
Entering Fluid Temp. (°F)	Entering Air Temp. (°F)	Total Capacity (MBtuH)	Sensible Capacity (MBtuH)	Sensible to Total Ratio	Power Input (kW)	Heat of Reject (MBtuH)	EER
50°	70°db	49.72	32.78	0.66	2.93	59.71	17.0
60°		47.82	31.78	0.66	3.22	58.80	14.9
70°		45.91	30.89	0.67	3.51	57.90	13.1
85°		43.05	29.74	0.69	3.95	56.54	10.9
100°		40.19	28.73	0.71	4.39	55.18	9.2
50°	75°db	53.29	39.23	0.74	2.94	63.33	18.1
60°		51.25	38.04	0.74	3.24	62.30	15.8
70°		49.21	36.99	0.75	3.53	61.26	13.9
85°		46.15	35.60	0.77	3.97	59.71	11.6
100°		43.09	34.41	0.80	4.41	58.16	9.8
50°	80°db	58.52	43.33	0.74	2.96	68.63	19.7
60°		56.28	42.02	0.75	3.26	67.41	17.3
70°		54.04	40.86	0.76	3.56	66.19	15.2
85°		50.69	39.34	0.78	4.00	64.35	12.7
100°		47.33	38.02	0.80	4.45	62.52	10.6
50°	85°db	63.74	47.48	0.74	2.99	73.93	21.3
60°		61.30	46.05	0.75	3.29	72.52	18.7
70°		58.87	44.77	0.76	3.59	71.11	16.4
85°		55.22	43.11	0.78	4.03	68.99	13.7
100°		51.57	41.67	0.81	4.48	66.87	11.5

HEATING EFT Range (Standard) 25°F to 80°F

Entering Fluid Temp. (°F)	Entering Air Temp. (°F)	Total Capacity (MBtuH)	Power Input (kW)	Heat of Abs. (MBtuH)	COP
50°	60°	55.26	3.92	41.89	4.1
60°		61.12	4.07	47.23	4.4
70°		66.98	4.22	52.57	4.6
80°		72.84	4.38	57.91	4.9
50°		70°	52.26	3.99	38.65
60°	57.80		4.14	43.66	4.1
70°	63.34		4.30	48.66	4.3
80°	68.87		4.46	53.67	4.5
50°	80°		48.74	4.07	34.83
60°		53.90	4.23	39.45	3.7
70°		59.05	4.39	44.06	3.9
80°		64.21	4.55	48.67	4.1

LOW TEMP HEATING

Antifreeze Required

25°	60°	39.82	3.54	27.75	3.3
30°		42.69	3.61	30.36	3.5
40°		48.43	3.76	35.58	3.8
25°	70°	37.67	3.60	25.39	3.1
30°		40.38	3.68	27.84	3.2
40°		45.81	3.83	32.73	3.5
25°	80°	35.15	3.67	22.60	2.8
30°		37.67	3.75	24.86	2.9
40°		42.73	3.91	29.37	3.2

Units are complete packages containing a compressor, reversing valve, expansion valve metering device, and heat exchangers. Also included are safety controls: Overload protection for motors, high and low refrigerant pressure switches and a solid state lock-out circuit. Optional UL approved internal electric heater, factory installed with primary thermal overload protection and magnetic contactors (208/230-1-60 only). Optional UL approved internal Heat Recovery Package and/or Ground Loop Pump with purge connections available.

Performance based on ARI/ISO rated air flow, fluid flow and voltage. For conditions other than rated, consult the FHP EAD selection software. Due to variations in installation actual performance may vary marginally from tabulated values.

As a result of continuing research and development, specifications are subject to change without notice.
GT054ip6mod2 Rev: 10-06

FHP MANUFACTURING COMPANY

601 N.W. 65th Court - Fort Lauderdale, FL 33309

Phone: (954) 776-5471 - Fax: (800) 776-5529

<http://www.fhp-mfg.com>



PACKAGED UNITS SPECIFICATION DATA SHEET

FHP MANUFACTURING HIGH-EFFICIENCY WATER SOURCE HEAT PUMPS

GT062 GEO-THERMAL

ELECTRICAL SPECIFICATIONS

Electrical Characteristics	Elect. Symbol	Compressor		Blower		Loop Pump		Min. Circuit Amps	Max. Fuse/ Breaker
		RLA	LRA	FLA	HP	FLA	HP		
208/230-1-60	-1	25.6	169.0	5.0	3/4	-	-	38.8	60
208/230-3-60	-3	17.7	123.0	5.0	3/4	-	-	27.3	45
460-3-60	-4	9.0	49.5	2.5	3/4	-	-	13.8	20
575-3-60	-5	7.2	40.0	2.6	3/4	-	-	11.6	15

MECHANICAL SPECIFICATIONS

Refrigerant: R-22			
Air Coil			
Square Feet	Rows Deep	Tube O.D.	Fins/Inch
4.50	3	3/8	14
Water Coil			
Type	Work Press		
Coaxial	450 psig		
Blower Size	Compr Type		
10x8 DD	Scroll		
Net Weight	Ship Weight		
376 lbs	402 lbs		

BLOWER PERFORMANCE

Available External Static Pressure (Inches of Water, Gauge. Wet Coil and Filter Included)												
Blower Speed	0.10	0.20	0.30	0.40	0.50	0.60	0.70	0.80	0.90	1.00	1.10	1.20
High	2160	2100	2030	1950	1870	1800	1730	1680	1640	1600	1550	1500
Medium	2110	2050	1990	1900	1820	1750	1690	1650	1600	1550	-	-
Low	2060	2000	1950	1850	1760	1700	1640	1580	-	-	-	-



ISO 13256-1 CERTIFIED PERFORMANCE DATA Rated at 2,000 CFM and 15.0 GPM

Water Loop				Ground Water				Ground Loop			
Cooling		Heating		Cooling		Heating		Cooling		Heating	
Capacity	EER	Capacity	COP	Capacity	EER	Capacity	COP	Capacity	EER	Capacity	COP
60,000	12.5	77,000	4.5	65,000	17.5	60,000	4.0	60,500	14.0	48,000	3.2

FLUID PRESSURE DROP

Fluid Flow (GPM)	Pressure Drop	
	(FOH)	(PSIG)
8	3.48	1.51
10	5.21	2.25
15	10.80	4.68
18	15.00	6.49
22	21.52	9.32

CAPACITY DATA All performance at 2,000 CFM and 15.0 GPM

COOLING

EFT Range (Standard)
45°F to 110°F

Entering Fluid Temp. (°F)	Entering Air Temp. (°F)	Total Capacity (MBtuH)	Sensible Capacity (MBtuH)	Sensible to Total Ratio	Power Input (kW)	Heat of Reject (MBtuH)	EER
50°	70°db	56.34	37.19	0.66	3.46	68.16	16.3
60°		54.75	36.44	0.67	3.85	67.89	14.2
70°		53.16	35.83	0.67	4.24	67.63	12.5
85°		50.78	35.13	0.69	4.82	67.23	10.5
100°		48.40	34.66	0.72	5.40	66.83	9.0
50°	75°db	60.37	44.48	0.74	3.48	72.26	17.3
60°		58.67	43.59	0.74	3.87	71.89	15.2
70°		56.97	42.86	0.75	4.26	71.52	13.4
85°		54.42	42.03	0.77	4.85	70.96	11.2
100°		51.87	41.47	0.80	5.43	70.41	9.6
50°	80°db	66.27	49.11	0.74	3.51	78.25	18.9
60°		64.41	48.13	0.75	3.90	77.73	16.5
70°		62.54	47.33	0.76	4.30	77.20	14.6
85°		59.75	46.42	0.78	4.89	76.42	12.2
100°		56.95	45.80	0.80	5.47	75.64	10.4
50°	85°db	72.17	53.80	0.75	3.54	84.24	20.4
60°		70.14	52.73	0.75	3.93	83.57	17.8
70°		68.12	51.85	0.76	4.33	82.89	15.7
85°		65.08	50.85	0.78	4.92	81.88	13.2
100°		62.04	50.17	0.81	5.52	80.87	11.2

HEATING

EFT Range (Standard)
25°F to 80°F

Entering Fluid Temp. (°F)	Entering Air Temp. (°F)	Total Capacity (MBtuH)	Power Input (kW)	Heat of Abs. (MBtuH)	COP
50°	60°	65.74	4.71	49.67	4.1
60°		73.88	4.88	57.24	4.4
70°		82.02	5.05	64.80	4.8
80°		90.16	5.21	72.37	5.1
50°		70°	62.16	4.79	45.80
60°	69.85		4.96	52.91	4.1
70°	77.54		5.14	60.01	4.4
80°	85.23		5.31	67.11	4.7
50°	80°		57.95	4.90	41.24
60°		65.11	5.07	47.80	3.8
70°		72.28	5.25	54.36	4.0
80°		79.44	5.43	60.92	4.3

LOW TEMP HEATING

Antifreeze Required

25°	60°	44.49	4.28	29.87	3.0
30°		48.48	4.37	33.57	3.3
40°		56.46	4.54	40.98	3.6
25°	70°	42.08	4.36	27.20	2.8
30°		45.85	4.45	30.68	3.0
40°		53.40	4.62	37.63	3.4
25°	80°	39.26	4.46	24.05	2.6
30°		42.77	4.54	27.26	2.8
40°		49.79	4.72	33.68	3.1

Units are complete packages containing a compressor, reversing valve, expansion valve metering device, and heat exchangers. Also included are safety controls: Overload protection for motors, high and low refrigerant pressure switches and a solid state lock-out circuit. Optional UL approved internal electric heater, factory installed with primary thermal overload protection and magnetic contactors (208/230-1-60 only). Optional UL approved internal Heat Recovery Package and/or Ground Loop Pump with purge connections available.

Performance based on ARI/ISO rated air flow, fluid flow and voltage. For conditions other than rated, consult the FHP EAD selection software. Due to variations in installation actual performance may vary marginally from tabulated values.

As a result of continuing research and development, specifications are subject to change without notice.
GT062ip6mod2 Rev: 10-06

FHP MANUFACTURING COMPANY

601 N.W. 65th Court - Fort Lauderdale, FL 33309

Phone: (954) 776-5471 - Fax: (800) 776-5529

<http://www.fhp-mfg.com>



PACKAGED UNITS SPECIFICATION DATA SHEET

FHP MANUFACTURING HIGH-EFFICIENCY WATER SOURCE HEAT PUMPS

GT070

GEO-THERMAL

ELECTRICAL SPECIFICATIONS

Electrical Characteristics	Elect. Symbol	Compressor		Blower		Loop Pump		Min. Circuit Amps	Max. Fuse/Breaker
		RLA	LRA	FLA	HP	FLA	HP		
208/230-1-60	-1	28.8	169.0	5.0	3/4	-	-	42.8	70
208/230-3-60	-3	19.1	123.0	5.0	3/4	-	-	29.1	45
460-3-60	-4	9.1	62.0	2.5	3/4	-	-	13.9	20
575-3-60	-5	7.2	50.0	2.6	3/4	-	-	11.6	15

MECHANICAL SPECIFICATIONS

Refrigerant: R-22			
Air Coil			
Square Feet	Rows Deep	Tube O.D.	Fins/Inch
6.00	3	3/8	14
Water Coil			
Type	Work Press		
Coaxial	450 psig		
Blower Size	Compr Type		
10x8 DD	Scroll		
Net Weight	Ship Weight		
396 lbs	422 lbs		

BLOWER PERFORMANCE

Available External Static Pressure (Inches of Water, Gauge. Wet Coil and Filter Included)												
Blower Speed	0.10	0.20	0.30	0.40	0.50	0.60	0.70	0.80	0.90	1.00	1.10	1.20
High	2260	2230	2200	2175	2140	2095	2040	1975	1920	1855	1790	1730
Medium	2180	2150	2125	2090	2050	2005	1955	1900	1845	1780	1700	-
Low	2130	2100	2075	2035	1990	1945	1890	1830	1760	1700	-	-



ISO 13256-1 CERTIFIED PERFORMANCE DATA Rated at 2,200 CFM and 18.0 GPM

Water Loop				Ground Water				Ground Loop			
Cooling		Heating		Cooling		Heating		Cooling		Heating	
Capacity	EER	Capacity	COP	Capacity	EER	Capacity	COP	Capacity	EER	Capacity	COP
68,000	12.5	82,000	4.6	76,000	18.7	66,000	3.8	69,000	13.9	53,000	3.4

FLUID PRESSURE DROP

Fluid Flow (GPM)	Pressure Drop	
	(FOH)	(PSIG)
8	3.60	1.56
10	5.38	2.33
15	11.16	4.83
18	15.50	6.71
22	22.24	9.63

CAPACITY DATA All performance at 2,200 CFM and 18.0 GPM

COOLING

EFT Range (Standard)
45°F to 110°F

Entering Fluid Temp. (°F)	Entering Air Temp. (°F)	Total Capacity (MBtuH)	Sensible Capacity (MBtuH)	Sensible to Total Ratio	Power Input (kW)	Heat of Reject (MBtuH)	EER
50°	70°db	66.66	44.08	0.66	3.69	79.24	18.1
60°		64.09	42.73	0.67	4.19	78.39	15.3
70°		61.53	41.53	0.68	4.69	77.53	13.1
85°		57.68	39.96	0.69	5.44	76.25	10.6
100°		53.83	38.60	0.72	6.19	74.97	8.7
50°	75°db	71.41	52.67	0.74	3.71	84.07	19.3
60°		68.67	51.07	0.74	4.21	83.05	16.3
70°		65.92	49.64	0.75	4.72	82.02	14.0
85°		61.81	47.77	0.77	5.47	80.48	11.3
100°		57.69	46.15	0.80	6.23	78.95	9.3
50°	80°db	78.37	58.14	0.74	3.74	91.13	21.0
60°		75.36	56.37	0.75	4.25	89.85	17.8
70°		72.35	54.80	0.76	4.75	88.58	15.2
85°		67.84	52.74	0.78	5.52	86.67	12.3
100°		63.32	50.95	0.80	6.28	84.75	10.1
50°	85°db	85.33	63.66	0.75	3.77	98.18	22.7
60°		82.06	61.73	0.75	4.28	96.66	19.2
70°		78.78	60.01	0.76	4.79	95.13	16.4
85°		73.87	57.76	0.78	5.56	92.85	13.3
100°		68.96	55.80	0.81	6.33	90.56	10.9

HEATING

EFT Range (Standard)
25°F to 80°F

Entering Fluid Temp. (°F)	Entering Air Temp. (°F)	Total Capacity (MBtuH)	Power Input (kW)	Heat of Abs. (MBtuH)	COP
50°	60°	71.29	5.02	54.16	4.2
60°		79.41	5.20	61.66	4.5
70°		87.52	5.38	69.16	4.8
80°		95.63	5.56	76.66	5.0
50°		70°	67.40	5.11	49.96
60°	75.07		5.29	57.00	4.2
70°	82.73		5.48	64.04	4.4
80°	90.40		5.66	71.08	4.7
50°	80°		62.83	5.22	45.00
60°		69.97	5.41	51.50	3.8
70°		77.11	5.60	58.00	4.0
80°		84.25	5.79	64.50	4.3

LOW TEMP HEATING

Antifreeze Required

25°	60°	50.01	4.57	34.41	3.2
30°		53.99	4.66	38.08	3.4
40°		61.94	4.84	45.42	3.7
25°	70°	47.29	4.65	31.41	3.0
30°		51.05	4.75	34.85	3.2
40°		58.57	4.93	41.74	3.5
25°	80°	44.11	4.76	27.87	2.7
30°		47.60	4.85	31.05	2.9
40°		54.60	5.04	37.41	3.2

Units are complete packages containing a compressor, reversing valve, expansion valve metering device, and heat exchangers. Also included are safety controls: Overload protection for motors, high and low refrigerant pressure switches and a solid state lock-out circuit. Optional UL approved internal electric heater, factory installed with primary thermal overload protection and magnetic contactors (208/230-1-60 only). Optional UL approved internal Heat Recovery Package and/or Ground Loop Pump with purge connections available.

Performance based on ARI/ISO rated air flow, fluid flow and voltage. For conditions other than rated, consult the FHP EAD selection software. Due to variations in installation actual performance may vary marginally from tabulated values.

As a result of continuing research and development, specifications are subject to change without notice.
GT070ip6mod2 Rev: 10-06

FHP MANUFACTURING COMPANY

601 N.W. 65th Court - Fort Lauderdale, FL 33309

Phone: (954) 776-5471 - Fax: (800) 776-5529

<http://www.fhp-mfg.com>